



testo 350 *M/XL*

Short Operation Instruction Manual

Rev. 11/03 Instrument Software Version 1.30



800-227-0729

www.testo.com

testo inc. 35 Ironia Rd. Flanders, NJ 07836
Fax: 973-252-1729, e-mail: info@testo.com

Contents

1	Description of the system components	1
1.1	The Analyzer Box	1
1.2	The Control Unit.....	3
	Operate the instrument with the Control Unit.....	4
	The Display	4
1.3	The probes.....	5
1.4	Attach the probe and the hose.....	5
	Flue gas probe	5
	Ambient temperature probe	6
1.5	Connect the Control Unit and the Analyzer Box	6
1.6	Remove the Control Unit from the Analyzer Box	6
1.7	AC Power and Battery Recharge	7
2	How to operate	8
2.1	First steps	8
2.2	Quick measurement procedure	9
2.3	Print data.....	10
	Print out current data	10
	Customize printout	11
2.4	Change date and time	14
2.5	Customize the display.....	16
3	Function keys	18
3.1	Assign a function to a function key	18
3.2	Display the second set of 4 function keys	18
4	Select a fuel	19
4.1	Change the fuel	19
4.2	CO dilution system.....	19
4.3	Select O ₂ reference value for automatic calculations	20
5	Memory	21
5.1	Save data.....	21
5.2	View & print data from memory	21
5.3	Delete one reading	23
5.4	Delete entire memory	24
6	Data management	25
6.1	Data storage in the Analyzer Box	25
6.2	Set up a new file or location.....	26
6.3	Delete a location or a file	27
7	Program automatic measurements	28
7.1	Set up an automatic measurement program	28
7.2	Manually start an automatic program	32
7.3	Stop the automatic program	32
7.4	Rerun a program.....	33



8	Maintenance	34
8.1	Calibration of gas sensors	35
	Warm-up	36
	Connect to calibration gas	38
	Adjust gas flow	38
8.2	Changing batteries in the Analyzer Box	39
8.3	Changing batteries in the Control Unit.....	39
8.4	Change printer paper.....	39
8.5	Changing filters	40
8.6	Remove condensate water	40
8.7	Changing measurement sensors.....	40
8.8	Condensate pump service	42
9	Appendix.....	43
9.1	Function key list	43
9.2	Screen display parameters	44
9.3	Menu structure for Control Unit.....	45
	(Continue) Menu structure for Control Unit.....	46
9.4	Menu structure for Analyzer Box	47
9.5	Sample measuring and rinsing cycle times	48
9.6	CO-Measuring ranges with different dilution steps.....	49
9.7	Error codes/diagnostics	50
9.8	Status and error indicators.....	51
9.9	Principles of calculations	52
	Units conversions.....	52
	Calculations	53
9.10	Technical data	56
9.11	Warranty periods	57

Precautions testo 350 M/XL (Analyzer Box)			
	Persons	System	Instrument
Power supply Do not ever disrupt the PE conductor either inside or outside of the instrument! Check the ID label to ensure that the model, mains voltage and output coincide with the actual conditions!	X		X
Disposing of the measuring cells There are nominal amounts of concentrated acid in the measuring cells. Therefore, dispose of as hazardous waste! Improper handling is hazardous!	X		
Storing the measuring instrument Never store the measuring instrument in rooms with solvents. Doing so runs the risk of destroying the measuring cells! Ensure that you observe the specified storage, transport and operating temperatures!			X
Rechargeable battery Fully recharge the battery before conducting the initial measurement and after the instrument has gone unused for several days. Recharge the battery every 4 weeks after longer periods of inoperation. The testo rechargeable battery pack for the Control Unit and logger should be inserted so that the label faces outward. Otherwise, there is the danger of a short circuit or reverse polarity should the isolation jacket become damaged.			X
Operating the probe When removing the probe from the flue, check that the probe is hot!	X		
Condensate outlet Aggressive condensate (acid) exits the condensate outlet. If the corresponding drainage facility (e.g. hose) is not attached, there is a hazard for person and property!	X		X
Service and maintenance The power plug must always be pulled before opening the housing. Danger of electric shock! Access the instrument internals must only be done by authorised personnel!	X	X	X
Non-permissible measurements Explosive or ignitable gas mixtures as well as gases that form ignitable mixtures when exposed to air must not be measured with the above-listed instruments!	X		
Test gas pressure A maximum of 50 mbar is permissible. Higher pressures increase the risk of destroying the gas sensors! Additionally, test gas must only be used in well-ventilated rooms!	X		X
Cleaning the instruments Avoid the penetration of water into the instrument at all costs!			X
Differential pressure probe When conducting measurements, observe the permissible measuring ranges; exceeding tolerance leads to destruction of the sensor!			X
Condensation Avoid exposing the instrument electronics to condensation.			X



Precautions testo 350 M/XL testo 454 (Control Unit)			
	Persons	System	Instrument
Alarm contact The alarm contact must not be integrated into safety-related process, as the contact poses a hazard for persons and property, the system and the instrument.		X	
Analog output The analog outputs must not be used to control/regulate safety-related processes. They are designed to supply data to recorders, etc. Danger of system malfunction!		X	X
Logger, powerbox Operating loggers and powerboxes beyond their specified limits can lead to expulsion of hydrogen (H ₂) from the battery pack. Danger of explosion!	X		
Entire system Do not connect any part of the system to live objects (i.e. supplied with voltage) for measurement. Danger of electrical shock!	X		
CO measurement Ensure that there is sufficient ventilation when measuring toxic gases (CO). Danger of poisoning!	X		
Power supply to entire system Always ensure that the entire system is supplied with sufficient power (fully charged batteries/rechargeable batteries, mains unit). Danger of the entire system becoming unstable!			X
EMC Exceptionally high amounts of electromagnetics interference can lead the deviations in reading accuracy that no longer conform to standard. Danger with connected analog/switch outputs!	X	X	
Process security for analog monitoring Very dynamic signals can overload processes. In order to stabilise process security for system with dynamic signals we recommend observing Namur recommendation NE43, which makes specifications regarding signal conditions. Danger of overloading systems!		X	
Condensation Avoid exposing the instrument and instrument electronics to condensation.			X

1 Description of the system components

The system provides complete simplicity, extreme versatility and absolute expandability for you.



The modular system testo 350 contains of 3 main components



Control Unit



Analyzer Box



Probe

1.1 The Analyzer Box

The Analyzer Box includes, sensors, pumps, batteries, electronics, Peltier gas preparation, all filters, memory and all necessary hardware for flue gas and stack gas measurements. The Analyzer Box performs the gas analysis and is self-contained for long-term testing. The Control Unit is also able to log data independently.

Top view:

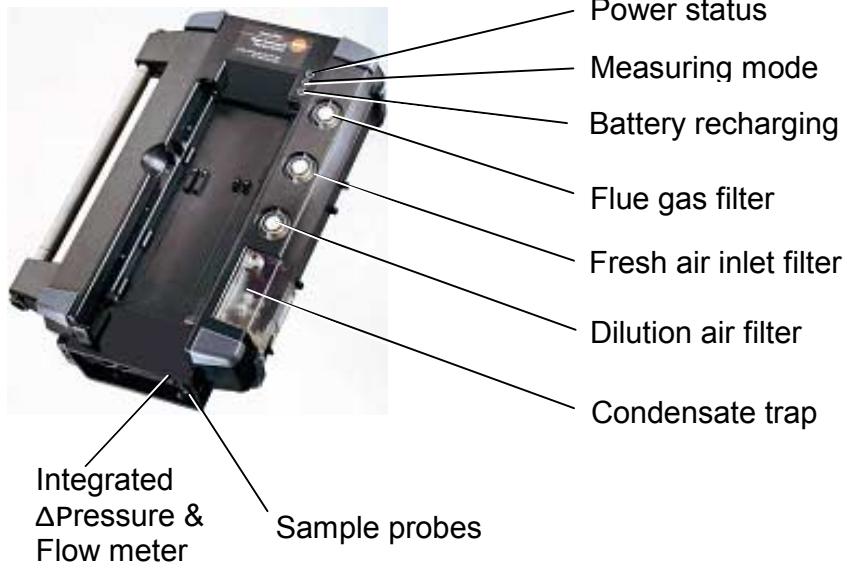

Side view:

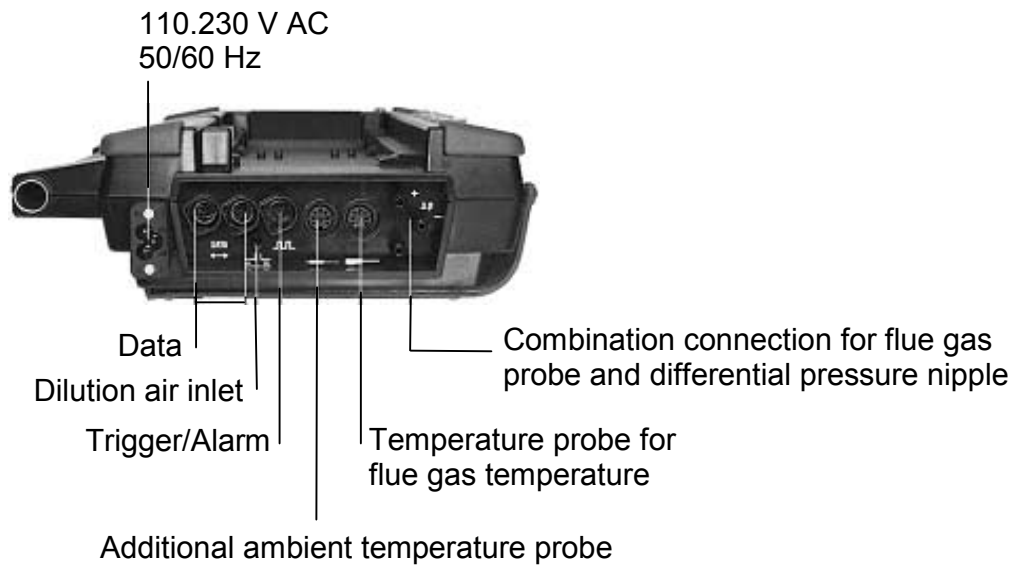

Differences between testo 350M and testo 350XL		
Description	testo 350M	testo 350XL
Max. gas sensors	4	6
Basic version equipped with	O ₂ , CO	O ₂ , CO, NO, NO ₂
Capable of extension with	NO, NO _{Low} , NO ₂ , SO ₂ , CO _{Low}	SO ₂ , H ₂ S, HC, NO _{Low} , CO _{Low}
Fresh air valve	Option	Standard
Trigger input	--	Option

1.2 The Control Unit

The Control Unit displays all flue gas measurements, up to 6 parameters simultaneously per page, as well as all instrument diagnosis and operating information. The Analyzer Box is controlled by the Control Unit and can be programmed as well. With the Control Unit you can operate the Analyzer Box remotely up to (6', 16' and 65' standard and more with optional powered cables). The Control Unit has memory up to 250.000 readings and an integrated printer for customized printouts. You operate the instrument with the 2 x 4 user-defined function keys, the keypad and, optionally, by touch-screen display. In addition, a multi probe input and an integrated Δ pressure probe are located in the Control Unit.



Operate the instrument with the Control Unit

You operate the instrument by pull-down menu driven selections. Customize the function keys with the most needed functions you desire, i.e. "Pump" or "Zero". The keyboard allows quick alphanumeric input, with the cursor keys or optional by touch screen pen.

The Control Unit is used for simple data management as well.

Data input...



...by key pad



... by touch screen (optional)

The Display

The Control Unit displays all flue gas measurements up to 6 parameters simultaneously on one screen.

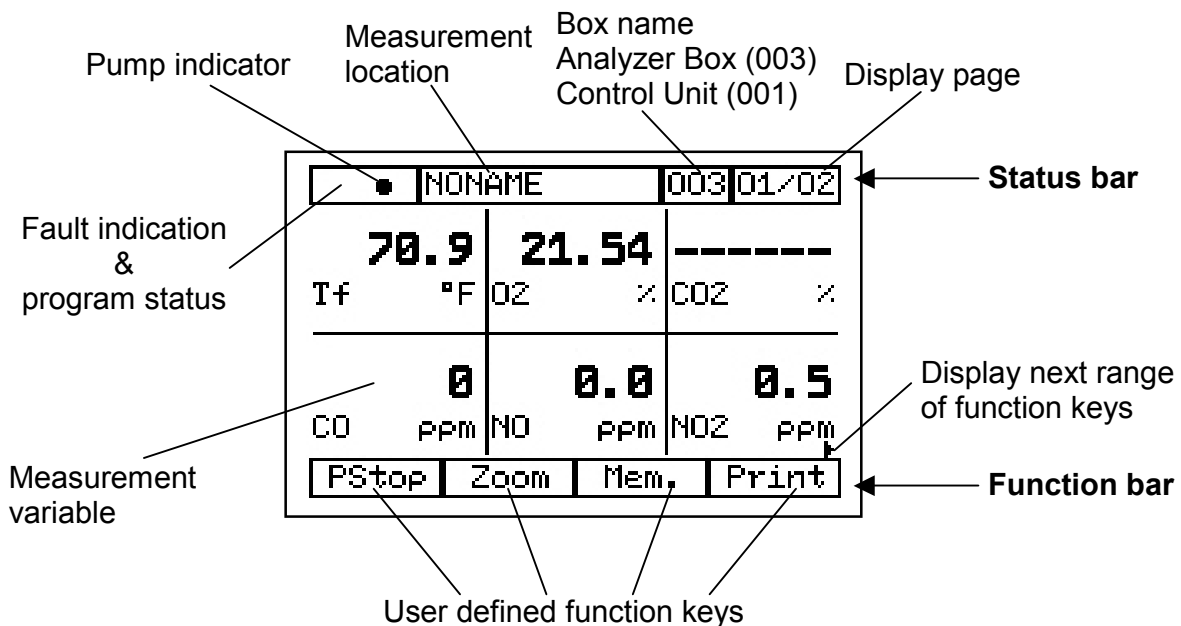

1.3 The probes

The probe removes hot sample gas from stack and transports it to the Analyzer Box. A thermocouple is integrated for a flue gas temperature measurement.

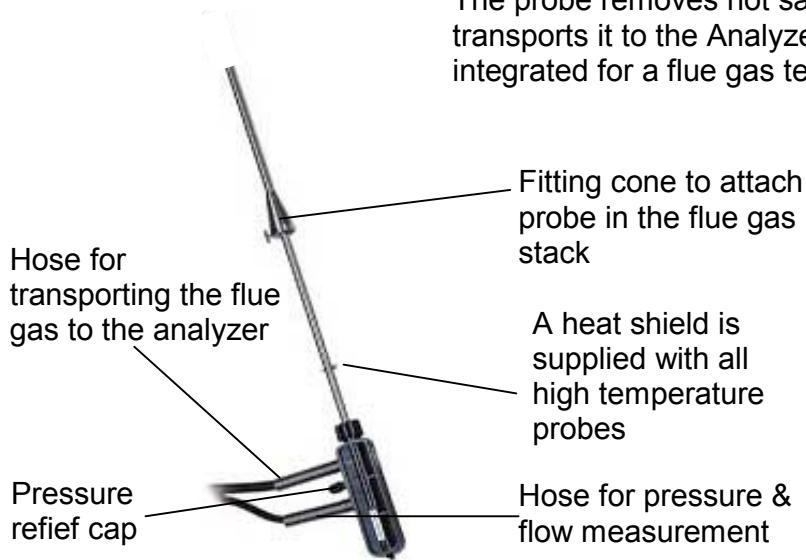

1.4 Attach the probe and the hose

Flue gas probe

1) Simply attach the probe as shown.



2) Press the connector firmly until the connector snaps into place.



3) Connect the probe thermocouple



4) Probe and thermocouple properly connected



Ambient temperature probe

For most applications, the mini ambient air probe is connected. For simultaneous inlet air temperature readings, a remote thermocouple can be connected here in this port.



1.5 Connect the Control Unit and the Analyzer Box



For a remote control measurement plug the data cable in one of the two "DATA" sockets at the Analyzer Box and in the "DATA" socket of the Control Unit. Different length connection cables between 6' and 65' and more are available. When the Control Unit is attached to the analyzer box, communication is maintained without the data cable.

1.6 Remove the Control Unit from the Analyzer Box

Press the tab on the left to release the hand held Control Unit from the Analyzer Box.



To replace the Control Unit press it on the analyzer until you hear a "click". Line up the arrows.

1.7 AC Power and Battery Recharge



The Analyzer Box has Nickel-Metal-Hydride rechargeable batteries that will last approximately 2-3 hours with all systems operating. For long-term measurements, or for recharging the batteries, attach the power cable as shown.

Note:

Battery charging does not take place when the analyzer is operating.

Analyzer Box status

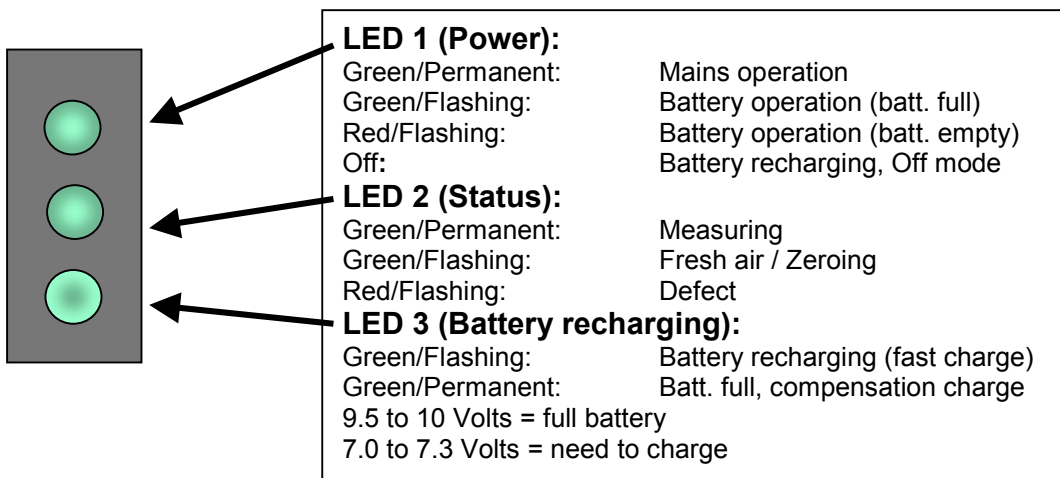

Note:

The lower LED on the Analyzer Box shows the status of the rechargeable batteries in the Analyzer Box.

Control Unit charge status

Note:

This display only shows the charge status of the Control Unit batteries.

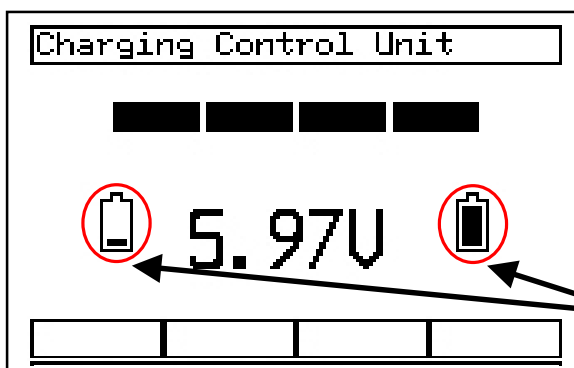

This screen is shown when the batteries are charging in the Control Unit. 100% appears (all 4 segment are black) when batteries are fully charged. The voltage of the Control Unit batteries are indicated on the screen.

Note:

The battery symbols don't change regardless of charge condition.

2 How to operate

2.1 First steps



- (1) Connect the probe to the instrument as seen in 1.4.
- (2) Connect the control unit and the analyzer box, see chapter 1.5.
- (3) Switch on the instrument by pressing the $\frac{1}{0}$ button.

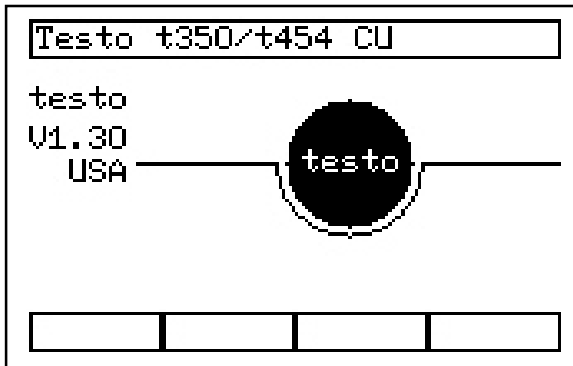

- (4) This screen appears.
- (5) After approximately 20 seconds the Instrument starts to run the “zero phase”.

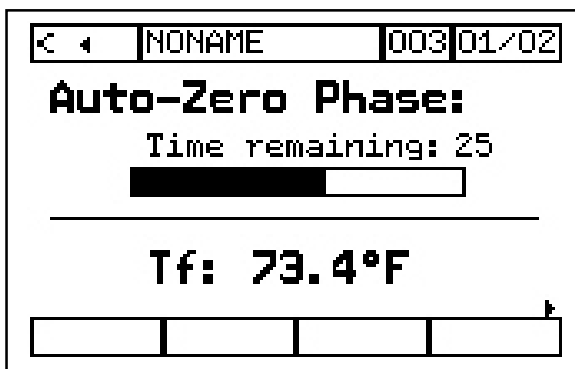



- (6) The zero phase lasts \approx 60 seconds.
- (7) During the zero-phase the sample probe thermocouple temperature is measured and displayed in the lower screen.



Note: Your screen might be slightly different to this screen because most of the displayed order is user defined.

NONAME		D03		01/02	
73.5		21.00		-----	
Tf	°F	O2	%	CO2	%
0		0.0		0.0	
CO	PPM	NO	PPM	NO2	PPM
Pump	Zoom	Mem.	Print		

- (8) This screen appears after the zero-phase.
- (9) The instrument is ready to measure.
- (10) You may change to the other pages by using the up  or the down  cursor.

For set up function keys see chapter 3 to customize the display see chapter 2.5.

Note:

For C_xH_y measurements you need 15 minutes for the sensor to reach stable operating temperature. Zero the analyzer before using.

2.2 Quick measurement procedure

For a quick measurement, the function keys “Pump”, “Mem.” and “Print” are recommended as shown below, however these can be customized see chapter 3.

NONAME		D03		01/02	
73.5		21.00		-----	
Tf	°F	O2	%	CO2	%
0		0.0		0.0	
CO	PPM	NO	PPM	NO2	PPM
Pump	Zoom	Mem.	Print		

- (1) To run a spot measurement press the function key below “Pump”, here the left function key.
- (2) The pump begins to run and a bull's eye will blink in the upper left status bar.
- (3) If you want to save the data, press the function key below “Mem.”, here the second on the right.
- (4) To stop the measurement press the function key below “PStop”, here the left function key (the same as for starting the pump).
- (5) When the pump stops, the values freeze on the screen.
- (6) To print out the data press the function key below “Print” (here the second on the left).
- (7) The print out appears.

Note:

For “how to” program and start a measurement program for long term measurements see section 7.1.

2.3 Print data

Print out current data

"Box" Address

←	NONAME	003	01/02
72.6	21.00	-----	
Tf	°F	O2	% CO2
0.0	0.0	-----	
CO	ppm	NOx	ppm Eff
Pump	Zoom	v On	Print

(1) To print out the current data displayed use the function key "Print". Here the first function key on the right.

Chapter 3.1 shows how to assign a function to a function key.

(2) See Chapter 3 for general use of the function keys.

Boxes and Addresses

This Analyzer can have more than two brains.

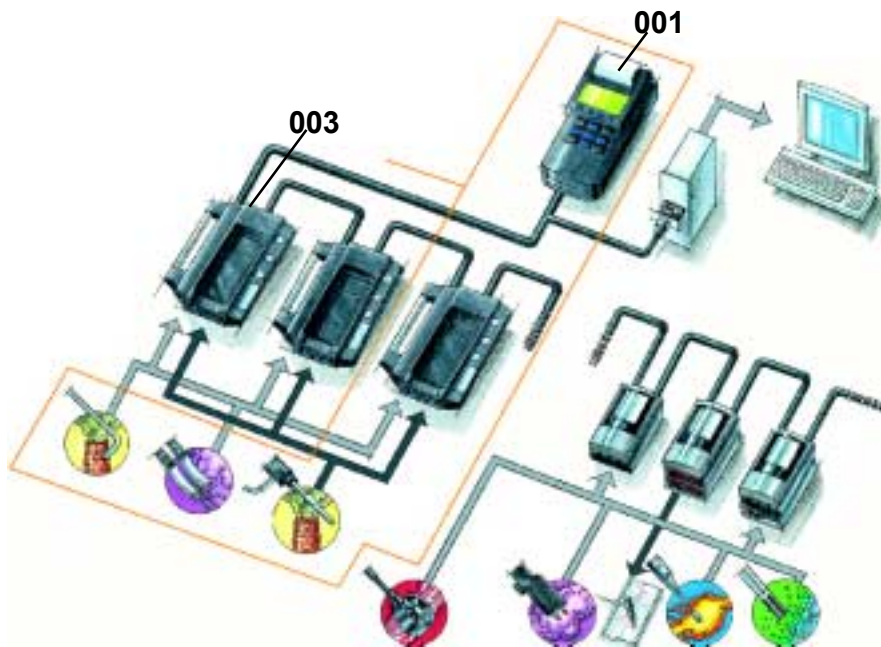

The testo 350 Control Unit can control and communicate with many devices such as multiple Analyzer Boxes and remote data logging "Boxes". When "001" is indicated in "Box" Address on the display, the Control Unit values are shown. When "003" is indicated in "Box" Address on the display (for this example) the analyzer on the left is in communication and the combustion values are shown.

To identify each "Box", a unique address is assigned and shown on the display. Use the or button to scroll and see the Control Unit or Analyzer Box display screen.

NOTE:
The Control Unit address is always "001"



Customize printout

You can customize 3 lines of text (i.e. company address, phone number,...) on the top of the printout and one line as a footnote.

Note:

This number may differ with different Analyzer Boxes

K		NONAME		003		01/02	
72.6		21.00		-----			
Tf	°F	O2	%	CO2	%		
0.0		0.0		-----			
CO	ppm	NOx	ppm	Eff	%		
Pump	Zoom	v On	Print				

1) To customize the printout you must change the screen from the Analyzer view (003) to Control Unit view (001). Access the screen by pressing the  or  button.

2) Use the  button, to scroll through the Analyzer screens.

K		NONAME		003		02/02	
-----		1.09		9.7			
ExA	%	Pump	l/m	Batt	U		
-----		-----					
ΔP	inW	loss	%				
Pump	Zoom	v On	Print				

Note:

The page changes as you scroll. A maximum of 6 user-defined screens are available.

K		NONAME		003		01/02	
Switch devices							
							
Pump	Zoom	v On	Print				

(3) The “Switch devices” screen quickly appears in preparation to display the Control Unit view.

Note:

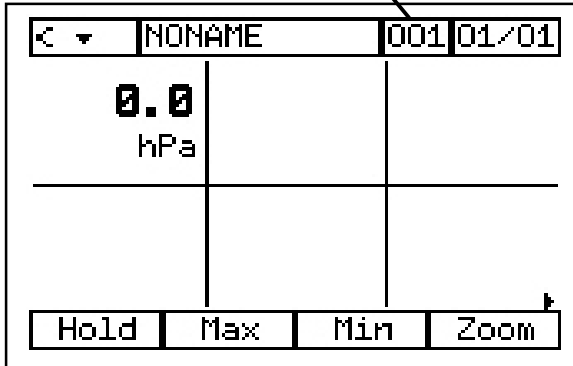

The “Switch device” function can be disabled by pressing the menu button and by following the screens: System → Configuration → Device scroll → Active device (see 9.3 Menu structure for Control Unit on page 46).

Note:
This change shows the Control Unit Address



(4) The screen of the Control Unit appears.

(5) Press the menu button .

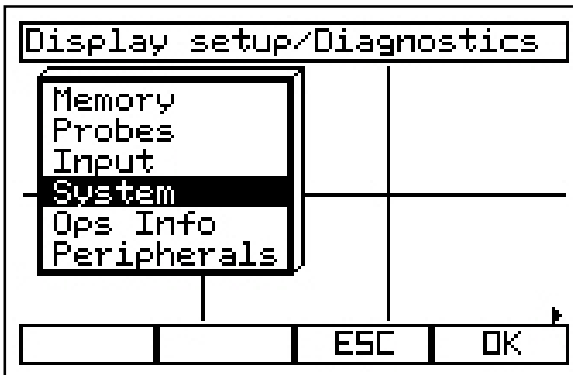

(6) Highlight "System" by using the cursor keys up  and down .

(7) Continue with "OK" .



(8) The main menu screen of the control unit appears.

(9) Press the menu button .

(10) Highlight "System" by using the cursor keys up  and down .

(11) Continue with "OK" .

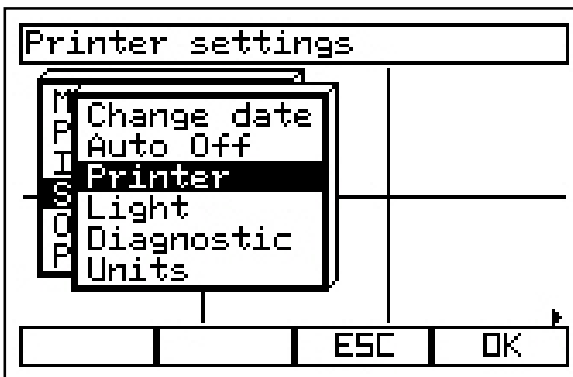

(12) A submenu appears.

(13) Highlight "Printer" by using the cursor keys up  and down .

(14) Continue with "OK" .

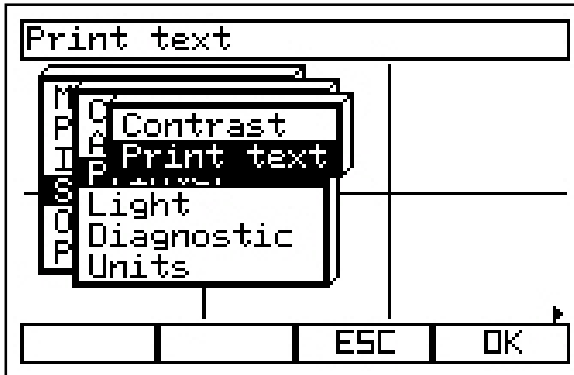

- (15) A submenu appears.
- (16) Highlight "Print text" by using the cursor keys up and down .
- (17) Continue with "OK" .

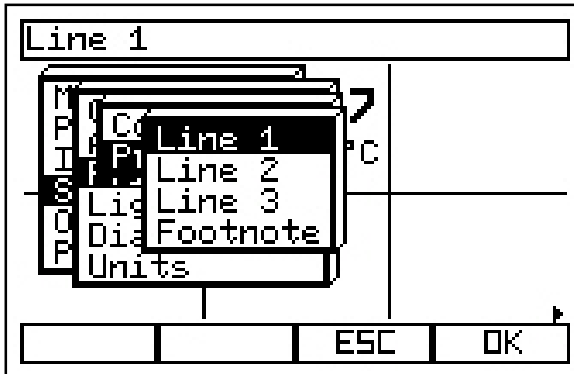

- (18) A submenu appears.
- (19) Highlight the line you want to insert a text by using the cursor keys up and down .
- (20) Continue with "OK" .

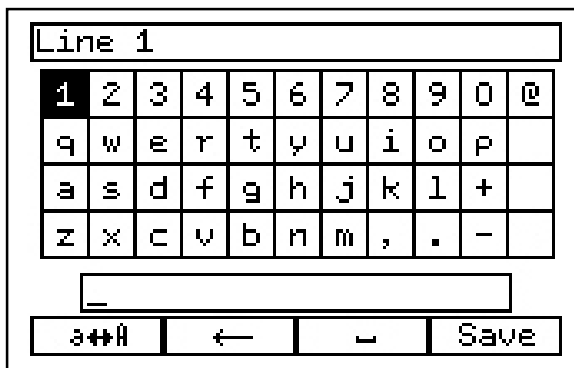

- (21) Now input the text. Highlight the letter by using the cursor keys up , down , right and left .
 - (22) Accept the highlighted letter over with "OK" .
- The letter is displayed in the field below the letter field.
- Function keys:**
- ⇧ Shift, alternates between upper and lowercase character selections
 - ← Delete the last letter
 - Space
- (23) To exit the screen and save the text press "SAVE", the right function key.

2.4 Change date and time



(1) To change date and time you must change the screen from analyzer view (003) to Control Unit view (001). Change the screen by pressing the "OK" button

(2) This screen appears.

(3) Highlight "Control Unit" by using the cursor keys up and down .

(4) Continue with "OK" .

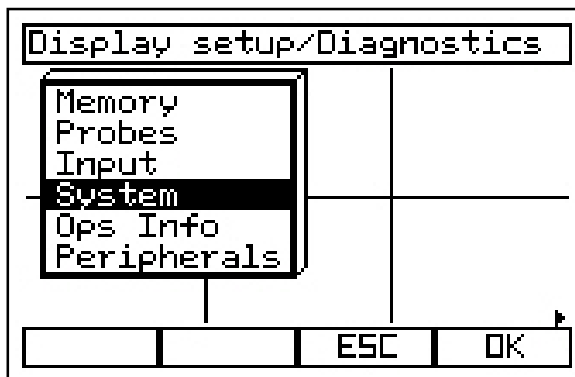

(5) The initial screen of the Control Unit appears.

(6) Press the menu button .

(7) Highlight "System" by using the cursor keys up and down .

(8) Continue with "OK" .

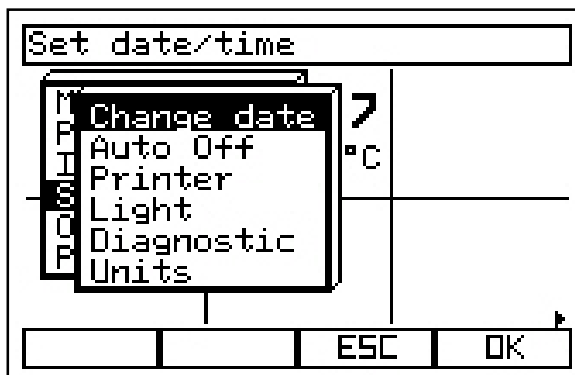

(9) A submenu appears.

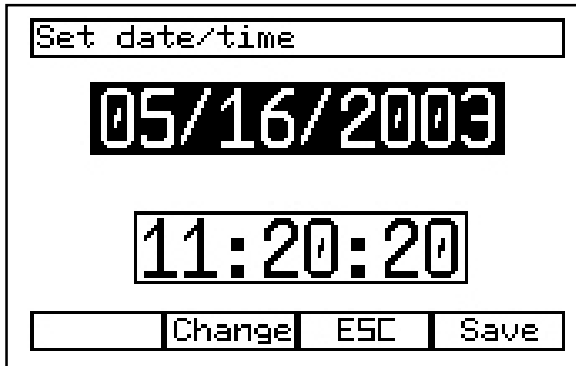

(10) Highlight "Change date" by using the cursor keys up and down .

(11) Continue with "OK" .

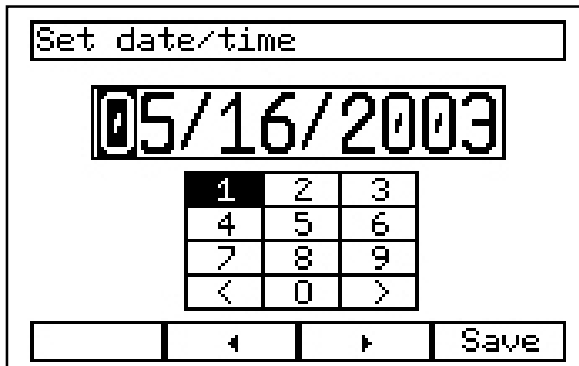

- (12) This screen appears.
 (13) To set date or time highlight the date or the time by using the cursor keys up and down.
 (14) Continue with “Change” the second left function key.







- (15) This screen appears.
 (16) Highlight the figure of the date/time you want to change by using the function keys right  and left , the two in the middle.
 (17) Continue with “Change” the second left function key.
 (18) Pick the figure in the numeric pad, which is displayed by using the cursor buttons of the keypad.
 (19) To confirm the number press the “OK”  button.
 (20) Continue with “Save”, the right function key.
 (21) Return to the initial screen with “End” and “ESC”.

Note:
 You are still in the Control Unit view. To get back to the analyzer view press “OK” and choose the Analyzer Box (003 etc.) and continue with “OK”.

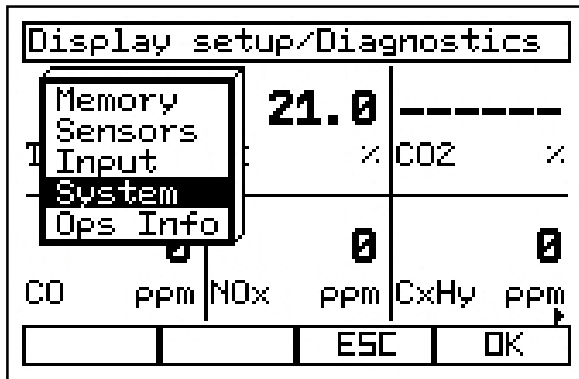

2.5 Customize the display

You'll be able to customize your screen so that the six most important parameters are displayed on the first screen in the units you need.

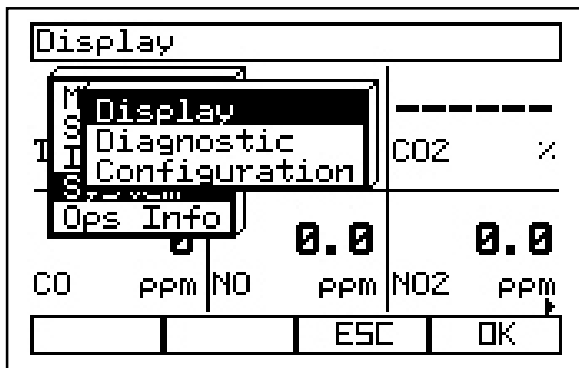

- (1) Press the menu button .
- (2) Highlight "System" by using the cursor keys up  and down .
- (3) Continue with "OK" .



- (4) This screen appears.
- (5) Highlight "Display" by using the cursor keys up  and down .
- (6) Continue with "OK" .

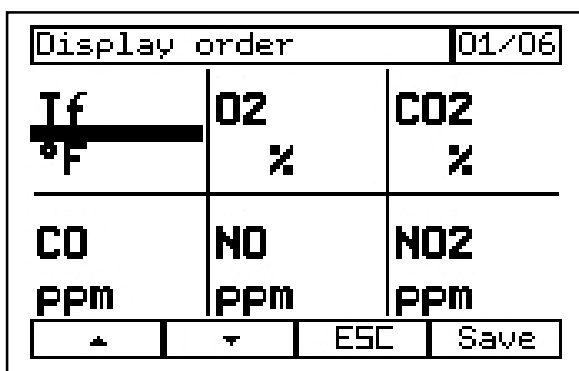



- (7) This screen appears.
- (8) The square with the black bar is the current square, where you can set up a parameter.
- (9) Use the cursor keys to select a square.
- (10) Continue with "OK" .

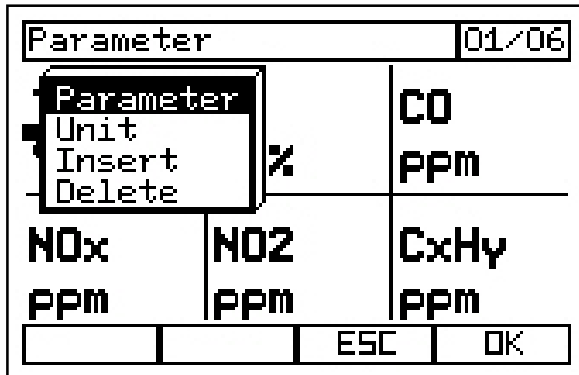

Note:

You can change to other screens if you use the function keys up  and down .

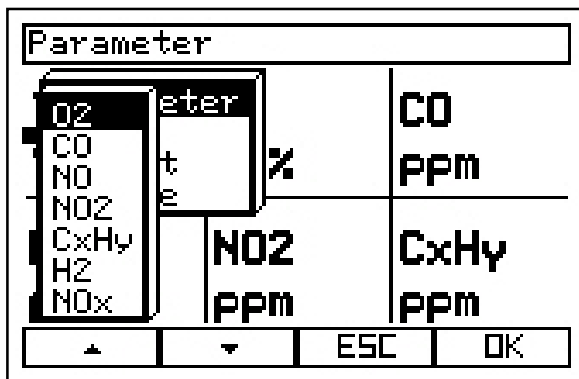

- (11) A submenu appears.
 (12) Highlight "Parameter" by using the cursor keys up  and down .
- (13) Continue with "OK" .



- (14) A submenu appears where all possible parameter are listed.
 (15) Highlight the parameter you want to set up by using the cursor keys up  and down .
- (16) Continue with "OK" .

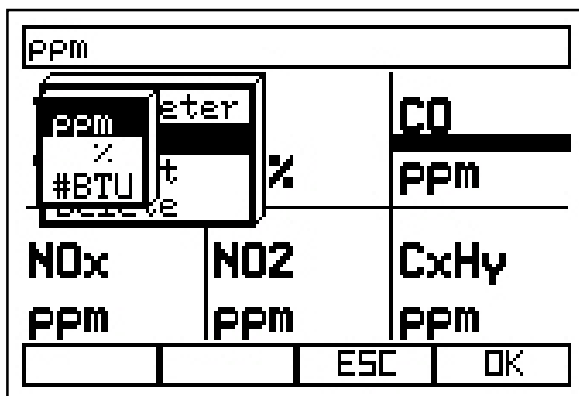

- (17) You are then asked to choose a unit for the parameter. Highlight a unit and continue with "OK" .
- (18) Press "SAVE" to complete and save the display. Press "ESC" to ignore all changes and return to original display.

Note:

You can change to other screen pages if you use the function keys up  and down  on the left side.

3 Function keys

With the function keys you can operate some of the main functions of the testo 350. You can select up to 8 functions (2 screens of 4 each).

3.1 Assign a function to a function key

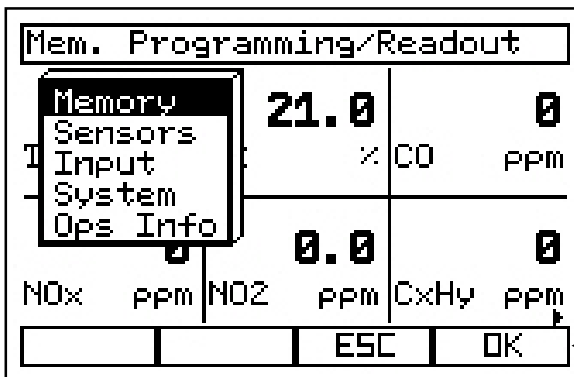

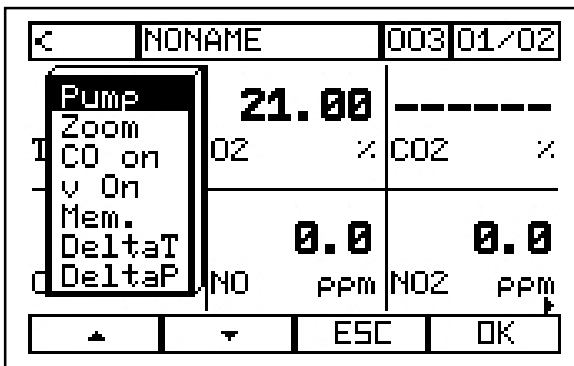

(1) To assign a function to a function key first press the menu button , releasing and *immediately* press the function key you want to assign or change. Wait a few seconds for the screens to change.

Function keys



(2) This selection menu appears on the screen. It displays the different “function” choices you have.

(3) Highlight the function, you want to assign to the function key by using the cursor keys up  and down  of the keypad or the two function keys on the left.

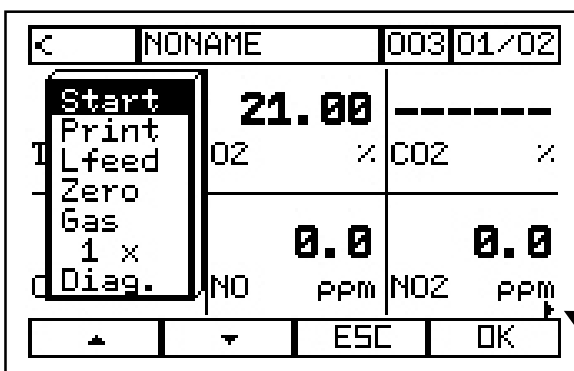



(4) Confirm your selection with OK



(5) The main screen appears and displays the function you have assigned above the function key.

3.2 Display the second set of 4 function keys

If the function, you need, is not visible in the current function key assignment, move to the second set of function keys with the right  or the left  cursor key. Shown by the tiny triangle in the screen above the right or left function key.

4 Select a fuel

The instrument comes with a pre-programmed selection of common fuels. The fuel parameters are used in the calculating values such as efficiency, excess air, and CO₂.

Note:

Base parameters like O₂, CO, NO_x, SO₂ etc. are not affected by fuel choice.

4.1 Change the fuel

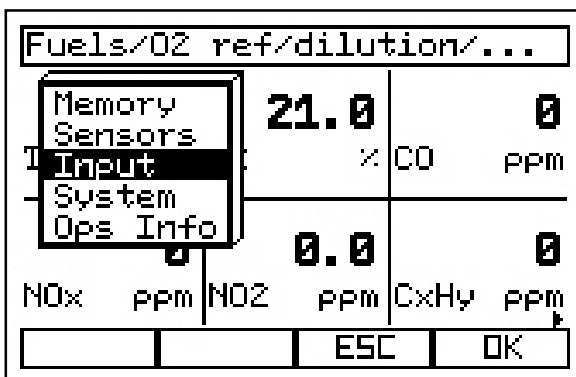

(1) To choose a fuel presses the menu button.

(2) The main menu appears.

(3) Highlight the item "Input" by using the cursor keys up \triangle and down ∇ .

(4) Confirm your selection with "OK" \square .

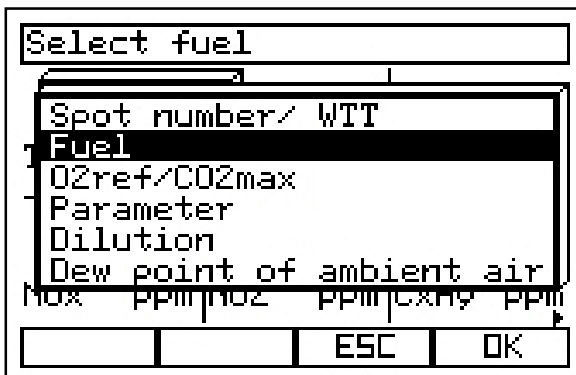

(5) A sub menu appears.

(6) Highlight the item "Fuel" by using the cursor keys up \triangle and down ∇ .

(7) Confirm your selection with "OK" \square .

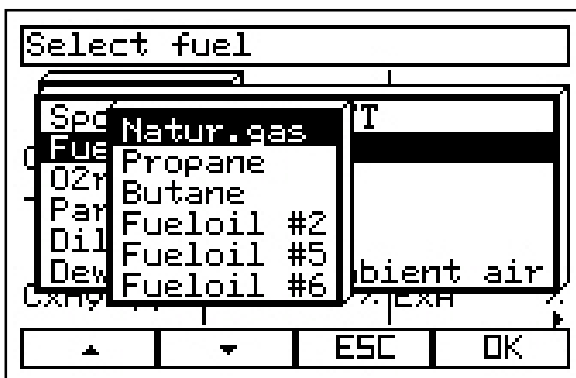

(8) A sub menu appears with a selection of most common fuels.

(9) Highlight the correct fuel. Use the cursor keys up \triangle and down ∇ .

(10) Confirm your selection with "OK" \square .

(11) The main screen will appear and the fuel is saved.

(12) If you burn fuels other than standard fuels, use "Userfuel" and insert the specific fuel factor data, see 4.3 Select O2 reference value

4.2 CO dilution system

If you are using the CO dilution system, see appendix for more information.

4.3 Select O₂ reference value for automatic calculations

For comparative purposes, many industries use values for emissions outputs that have been corrected to a standard O₂ reference value (e.g. turbines often use 15% O₂ while boilers and reciprocating engines often use 3%). Follow these steps to change the O₂ reference values.

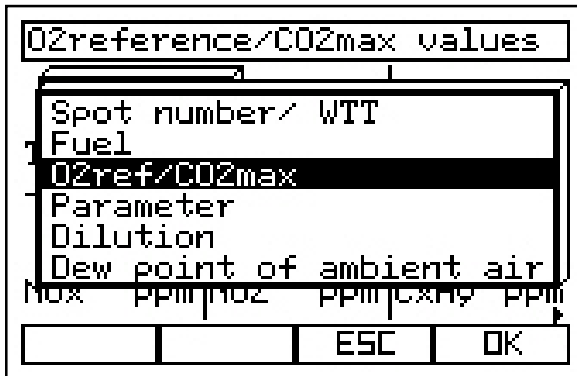

(1) Select “Input ” from the main menu using the up and down keys.

(2) Select “O₂ref/CO₂max and confirm with OK .

(3) Open the main menu and select “O₂ref/CO₂max” by using the cursor keys up and down .

(4) Confirm your selection with “OK” .

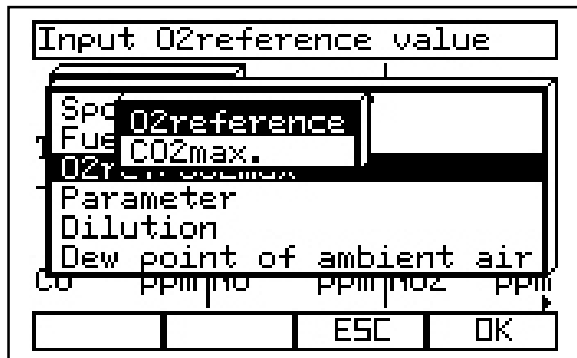

(5) A sub menu appears.

(6) Highlight the item “O₂reference” by using the cursor keys up and down .

(7) Confirm your selection with “OK” .

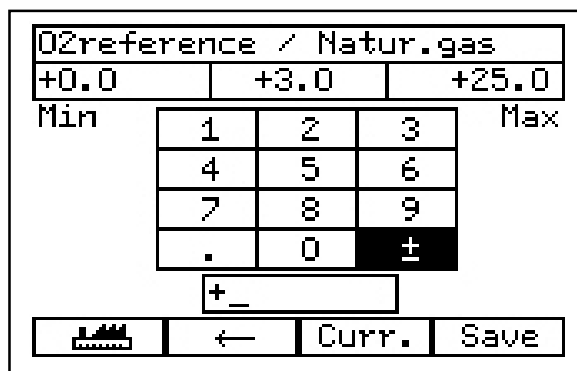

(8) A sub menu appears.

(9) Highlight the required value by using the cursor keys up, down, left and right.

(10) Confirm your selection with “OK” then choose next value.

(11) Press “SAVE” to confirm and store value

Note:

O₂ reference only effects the readings of parameters like cNO, and cCO. The lower case “c” refers to corrected by the reference value.

Note:

The next screen for CO₂ max is automatically displayed. Do not confuse this with the O₂ reference screen.

5 Memory

You can save the current data displayed on the screen. They will be saved in the location shown on the status bar, in this case "NONAME".

5.1 Save data

Note:
This shows your location

←	NONAME	003	01/02
73.5	21.00	-----	
Tf °F	O2 %	CO2 %	
0	0.0	0.0	
CO ppm	NO ppm	NO2 ppm	
Pump	Zoom	Mem.	Print

1) To save the current data on the displayed on the screen you have to press "Mem.", here the second right function key.

5.2 View & print data from memory

Note:



Printing data is only possible when the automatic measuring program is not active.

See chapter "7.3 Stop the automatic program" to stop or delete a measurement program.

Mem. Programming/Readout			
Memory	21.00	-----	
Sensors		CO2 %	
Input			
System			
Ops Info			
0	0.0	0.0	
CO ppm	NO ppm	NO2 ppm	
		ESC	OK

1) To access the memory first press the menu button .

2) The main menu appears.

3) Highlight the item "Memory" by using the cursor keys up  and down .

4) Confirm your selection with "OK" .

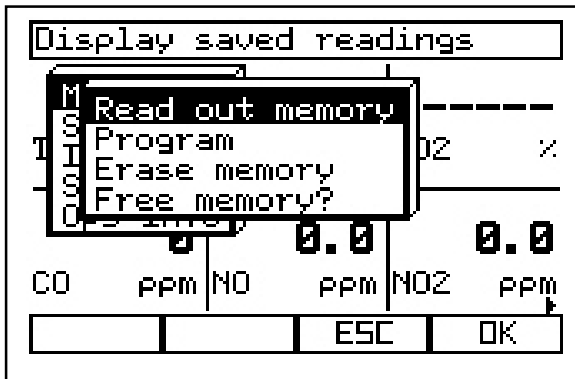

- 5) A submenu appears.
- 6) Highlight the item “Read out memory” by using the cursor keys up and down .
- 7) Confirm your selection with “OK” .

Note:

Here could appear a list of all saved readings, depending on your measurement.



- (8) The saved reading in the present location, here: NONAME appears.
- (9) Highlight the reading to display by using the cursor keys up and down .
- (10) Confirm your selection with “OK” .

(11) If you need more information about the reading press “Info” the right function key. A screen with some information appears.

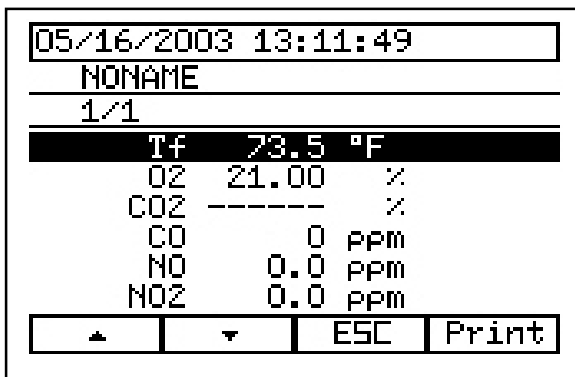



- (12) The values are displayed on the screen.
- (13) To display the next page use the cursor keys up and down .
- (14) To print the reading press the right function key “Print”.
- (15) To return to the initial screen press “ESC” .





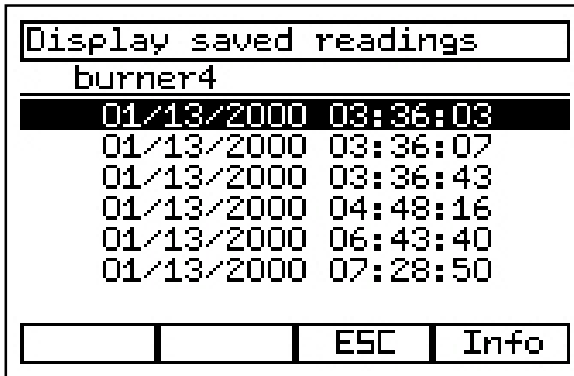

5.3 Delete one reading

You have the choice between deleting only one reading and deleting the whole memory. Data files and locations may be deleted as well.

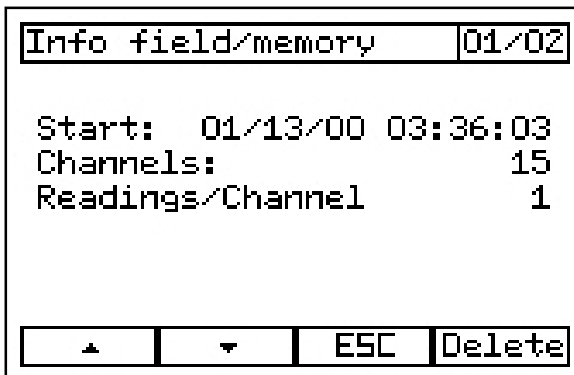

- (1) To delete a reading go to display saved readings. You get there via the main menu, "Memory", "Read out memory". For details see "View & print data from memory".
- (2) Highlight the reading you want to delete by using the cursor keys up  and down .
- (3) To delete the reading press "Info" the right function key.







- (4) The Info field/memory appears.
- (5) To turn the pages use the cursor keys up  and down .
- (6) To delete the reading press "Delete" the right function key.
- (7) The reading is deleted.
- (8) To return to the initial screen press "ESC" .

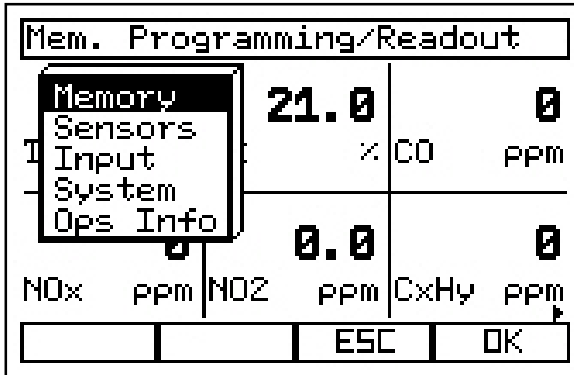

5.4 Delete entire memory

Caution: the entire memory of the Analyzer Box or the Control Unit will be deleted regardless of which location or file the readings are stored. The memory that will be deleted depends on the unit in which you are currently working (e.g. Analyzer, Control Unit, etc.)

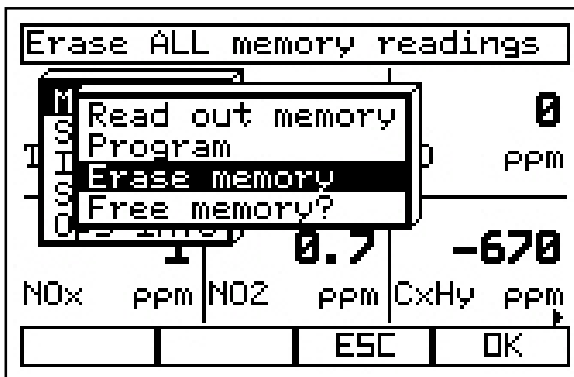

- (1) To delete the memory press the menu button .
- (2) The main menu appears.
- (3) Highlight the item "Memory" by using the cursor keys up  and down .
- (4) Confirm your selection with "OK" .



- 5) To delete the memory highlight "Erase memory" by using the cursor keys up  and down .
- 6) Confirm your selection with "OK" .



6 Data management

With the testo 350 you can organize your measurement data in an easy to use structure. The structure contains **files**, and **locations** for measurement data.

Measurement data can only be saved in locations.

The Control Unit is the master of the system meaning every file or location you set up is displayed in the Control Unit. But you'll be able to setup files or locations in the Analyzer Box as well.

Recommendation: If you measure flue gas parameters, use the memory and the location structure in the Analyzer Box.

6.1 Data storage in the Analyzer Box

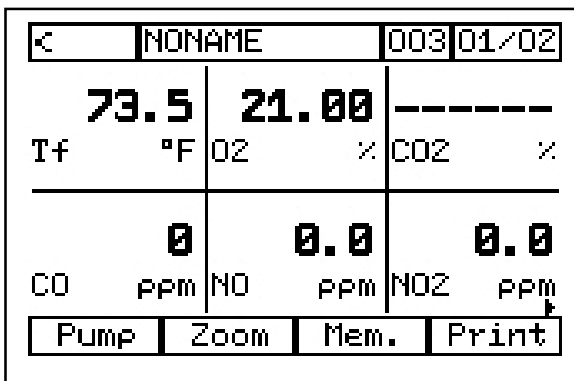

(1) Emission data is stored in the Analyzer Box.

(2) To view the data press "OK" and then the "Left arrow" or, if you have a Touch-screen option, select the "Location" name, in this case "NONAME", located on the status bar on the top of the screen.

NOTE:

Data can only be stored in a location, not in a file.

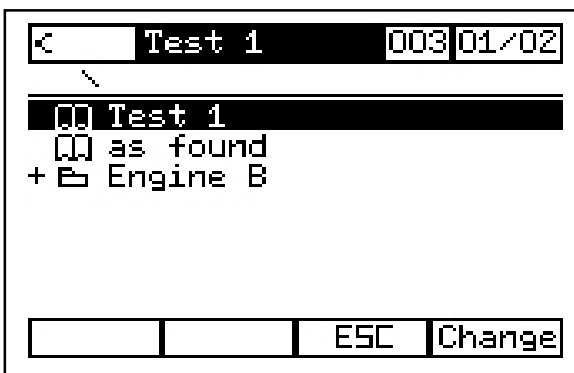

(6) A similar screen appears to create file and location names.

(7) On this screen the files and location of the 1st level are displayed.

(8) To open a folder or select a location highlights the file/location and press "OK" .

(9) You'll return to the main screen.

(10) The current location is displayed in the status bar, here "Test 1".

Explanation:

= file

= location = *data storage location*

* = location contains data

+ = file contains locations or data

6.2 Set up a new file or location

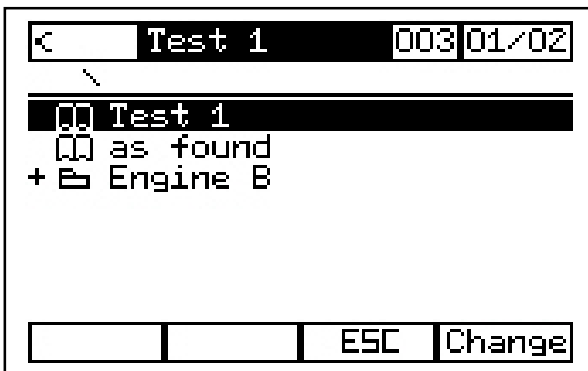



(1) To set up a new file or location press “Change”, the right function key.

(2) To get to the 1st level of files and locations press “ESC”.





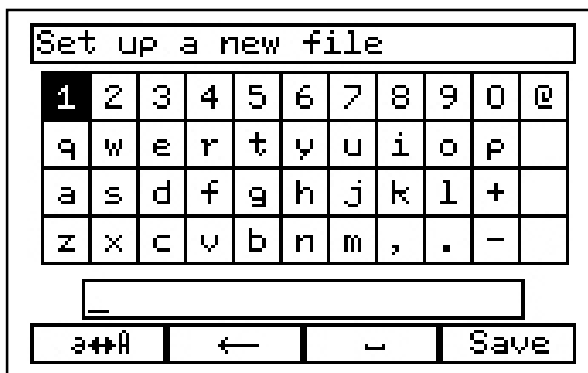

(3) The menu appears.

(4) Highlight “New file” or “New location” by using the up  and down  cursor key.

(5) Continue with “OK” .



(6) Now you’ll be able to put in the text.

(7) Highlight the letter by using the cursor keys up , down , right  and left .

(8) Accept the highlighted letter with “OK” .

The letter is displayed in the field below the letter field.

Function keys:

 Shift, enables capital letter

 Delete the last letter

 Space

(9) To exit the screen and save the text press “SAVE”, the right function key.

6.3 Delete a location or a file

If you delete a location all data that are stored in the location will be deleted as well. You can just delete a location or an empty file. If you want to delete a file with all the locations you must delete first the locations and afterwards the file.

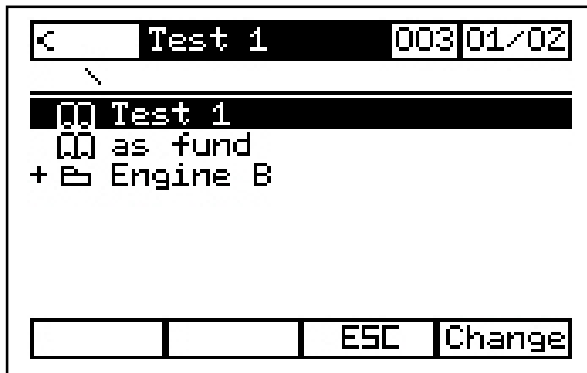

(1) Pick the file or location you want to delete.

How to get to the 1st level of files and locations and how to select a file or location, see 6.1 and 6.2.

(2) To delete an empty file or a location pick the file or location and press “Change”, the right function key.

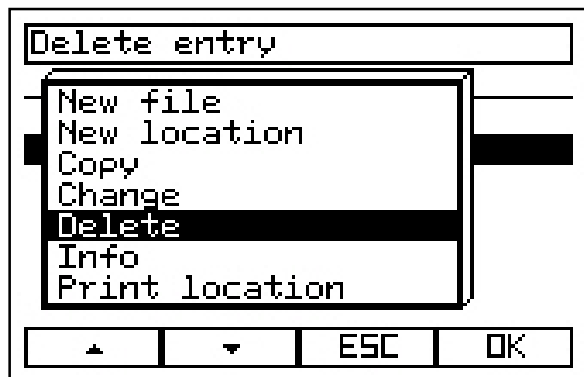

(3) The menu appears.

(4) To delete the file or location you picked up highlight “Delete” by using the cursor keys up and down .

(5) Continue with “OK” .

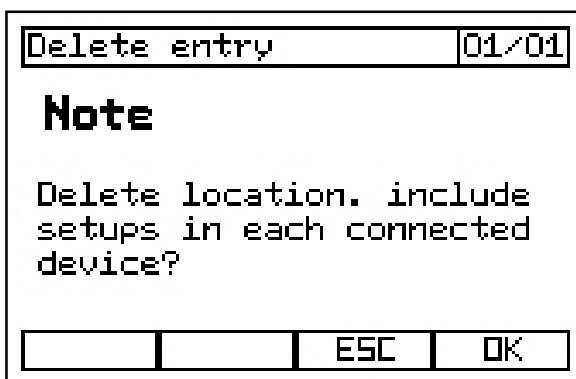

(6) A note appears.

(7) If you are sure to delete the file or location continue with “OK” .

(8) If you don't want to delete a file or a location, press the escape button “ESC” .

(9) Return to the initial screen with “ESC” .

7 Program automatic measurements

You can operate the testo 350 automatically by setting up a measurement program. Measurement program configures the measurement start + stop-cycle and the fresh air purge cycle, calculates average values etc.

A program can be set-up in the Analyzer Box or Control Unit. Be sure to select the Analyzer Box for combustion testing.

7.1 Set up an automatic measurement program

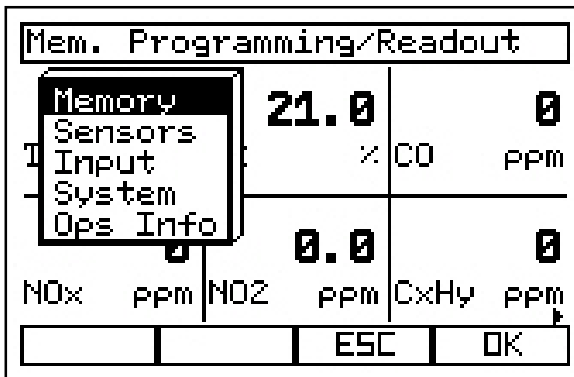



(1) To set up a program press the menu button .

(2) Pick "Memory" by using the cursor keys up  and down .

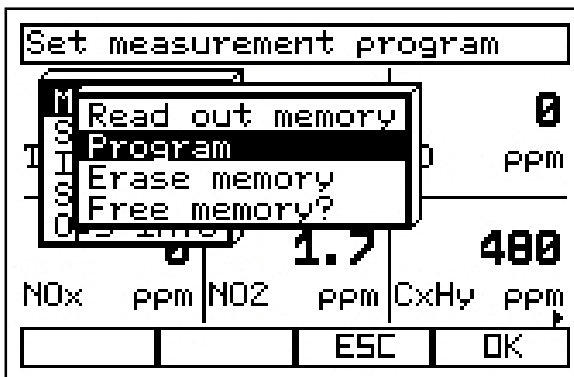
(3) Continue with "OK" .





(4) A submenu appears.

(5) Highlight "Program" by using the cursor keys up  and down .

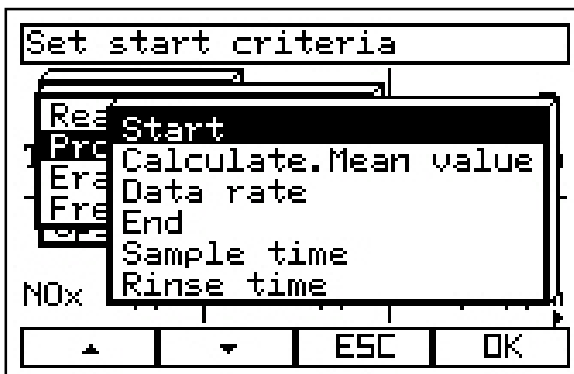
(6) Continue with "OK" .



(7) A submenu appears.



(8) Pick "Start" by using the cursor keys up  and down .

(9) Continue with "OK" .

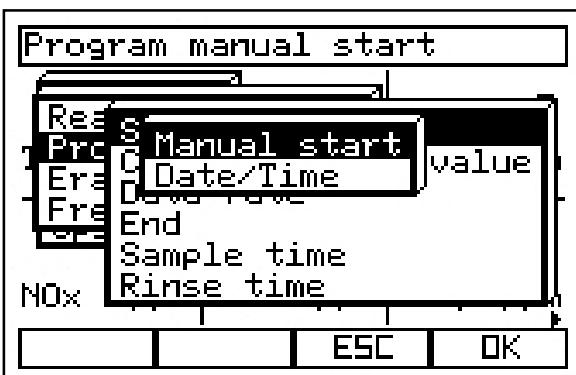

(10) You will be guided thru the menu to set up an automatic measurement program.

Cont. 7.1 Set up an automatic measurement program





- (11) Decide how to start the program whether by keystroke (function key “Start”) or by date/time.
- (12) Make your decision by using the cursor keys up  and down .
- (13) Continue with “OK” .
- (14) If you have chosen “Manual start” go to step No. 22.



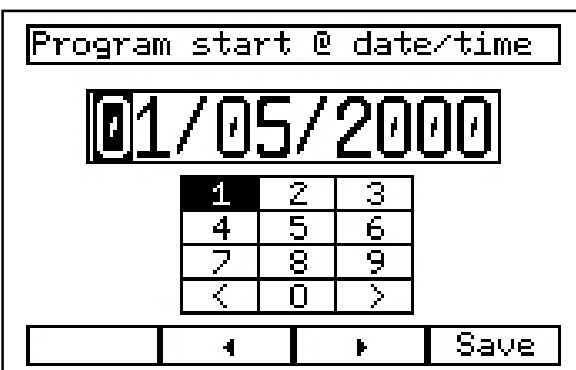

- (15) If you have chosen “Date/Time” this screen appears.
- (16) To set the start date/time highlight the date or the time by using the function keys up  and down  and continue with “Change” the second function key on the left.

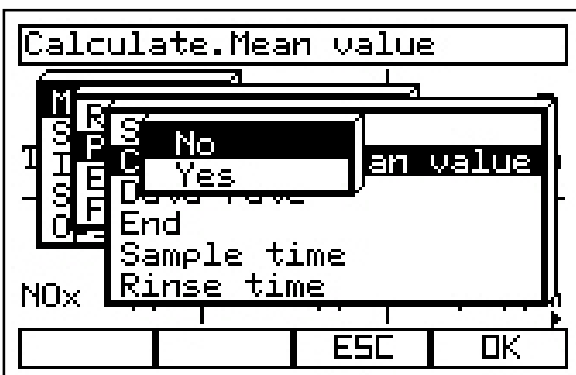

- (17) This screen appears.
- (18) Highlight the figure of the date/time you want to set up by using the function keys right  and left .
- (19) Pick the figure in the numeric pad, which is displayed by using the cursor buttons of the keypad.
- (20) To accept a figure, press the “OK”  button.
- (21) Continue with “SAVE”, here the right function key.



- (22) Navigate with the cursor button up  and down .
- (23) Only the average-mean value is calculated and stored, if you choose “Yes”. The average is based on data logged every second for the selected time interval.
- (24) Continue with “OK”.

Cont. 7.1 Set up an automatic measurement program

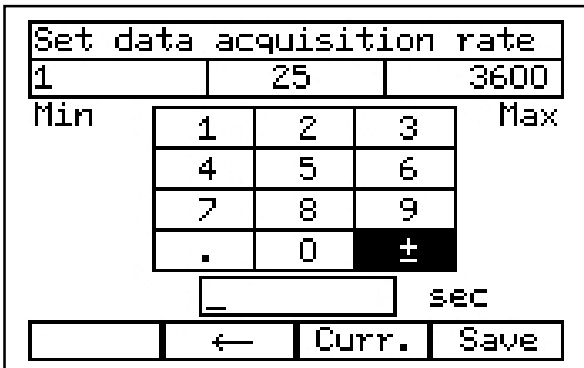

(25) This screen appears.

(26) Insert the data acquisition rate (seconds) by using the cursor keys to highlight a number and the "OK"

button to confirm.

The minimum and the maximum value are displayed on the left and on the right upper screen. In the middle of these, the current value is displayed. To accept over the current value press "Curr." the second function key on the right.

(27) To confirm your settings press the function key "SAVE", here the right function key.

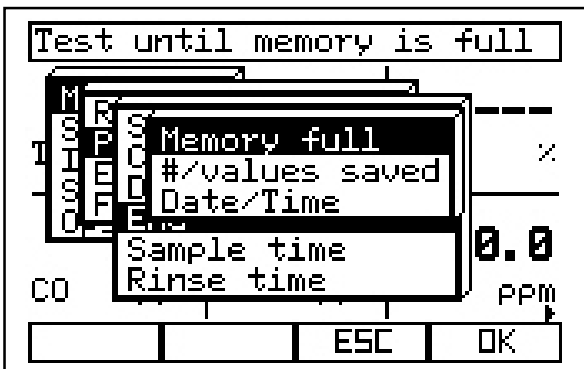

(28) The following screen determines how many values should be saved.

(29) You have the choice: until the memory is full or set up a No. of values saved or by time and date.

(30) Highlight your choice and continue with "OK".

(31) If you've set "Memory full" go to step No. 35.

Note:

values saved – will determine how long the program will operate according to the data acquisition rate, i.e.:

three 15 min tests saving every one minute = 45 values saved.

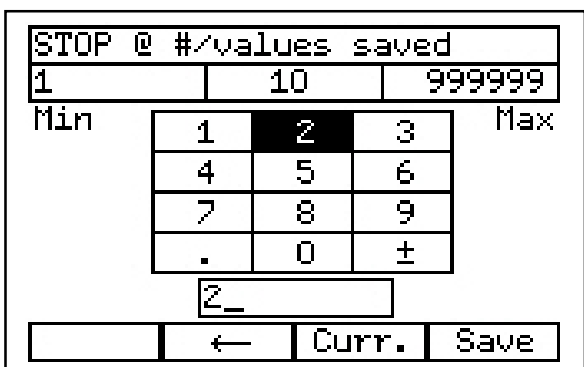

(32) Insert the number of values until the program ends.

(33) Use the cursor buttons to highlight a number and "OK" to take it over.

(34) Continue with "SAVE" the right function key.



Cont. 7.1 Set up an automatic measurement program

Sample time				
+2	+24	+240		
Min	1	2	3	Max
	4	5	6	
	7	8	9	
	.	0	±	
	+240_			min
	←	Curr.	Save	

- (35) Select the sample time cycle.
- (36) Use the cursor buttons to highlight a number and press "OK" to confirm.
- (37) Continue with "SAVE" the right function key.

Rinse time				
+5	+5	+1440		
Min	1	2	3	Max
	4	5	6	
	7	8	9	
	.	0	±	
	+5_			min
	←	Curr.	Save	

- (38) Select the rinse time cycle.
- (39) Use the cursor buttons to highlight a number and press "OK" to confirm.
- (40) Continue with "SAVE" the right function key.

Info	01/02		
Measur. program: Inactive			
Start:	Manual start		
End:	#/values save 2		
Data rate:	1 sec		
Sample time:	240 min		
Rinse time:	5 min		
Calculate.Mean value:	1 sec		
▲	▼	ESC	OK

- (41) The info screen shows all set parameters.
- (42) To display the second screen use the up or down button.
- (43) Accept the program and continue with the function key "OK" the right function key.

7.2 Manually start an automatic program

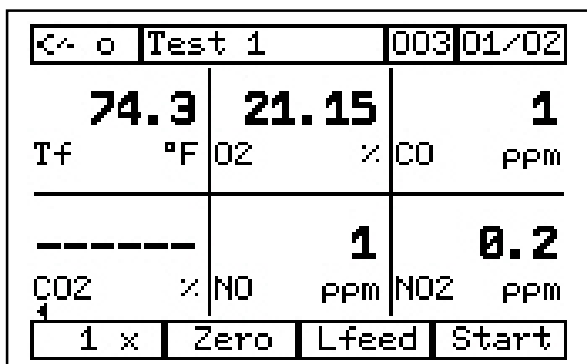



- (1) For running a measurement program put the function key “Start” on the screen, see 3 Function keys.
- (2) To start the measurement program press “Start”, here the right function key.
- (3) When the program is running the function key “Start” changes to “Stop”.

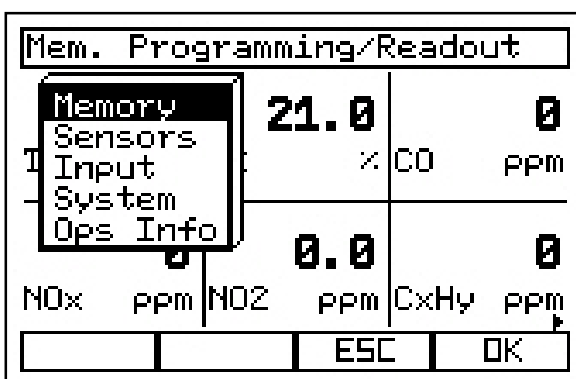

7.3 Stop the automatic program





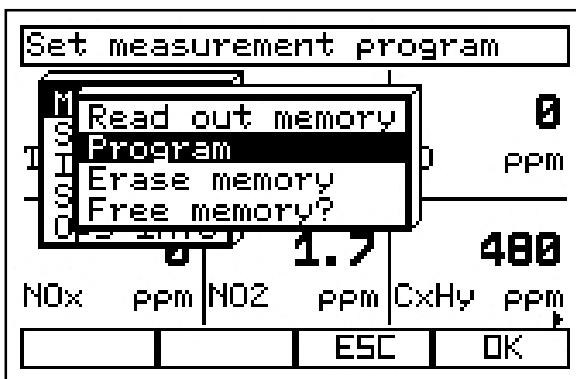

There are two ways to stop a measurement program; by the function key or with the menu item “Delete”.

- (1) To stop the measurement program press the function key “Stop”
- (2) To delete the measurement program press the menu button .
- (3) Continue with “OK” .

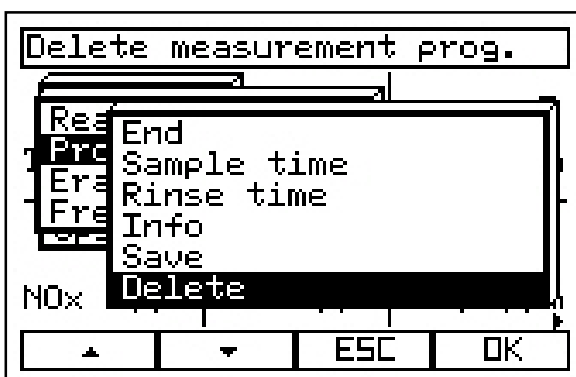

- (4) A submenu appears.
- (5) Highlight “Program” by using the cursor keys up  and down .
- (6) Continue with “OK” .



- (7) A submenu appears.
- (8) Highlight “Delete” by using the cursor keys up  and down .
- (9) Continue with “OK” .
- (10) The measurement program is now inactive.
- (11) Press “ESC”  to return to the initial screen.

7.4 Rerun a program

Push the “START” function key again (V1.30 and beyond) or do the following.

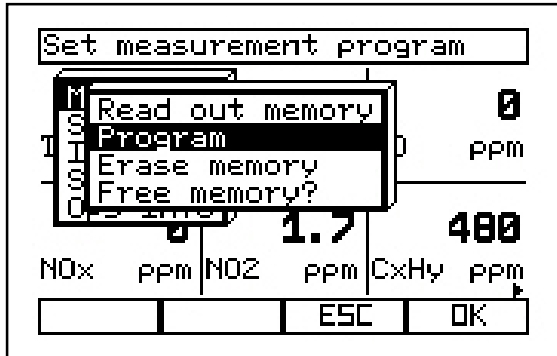

(1) Open the main menu with the  button.

(2) Select Memory with .

(3) Highlight Program with .

(4) Select with .

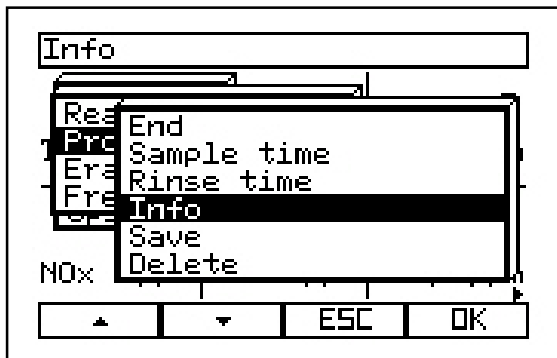

(5) Use the  to select Info

NOTE!

Info appears on page 2 of the drop down menu

(6) Select Info with .

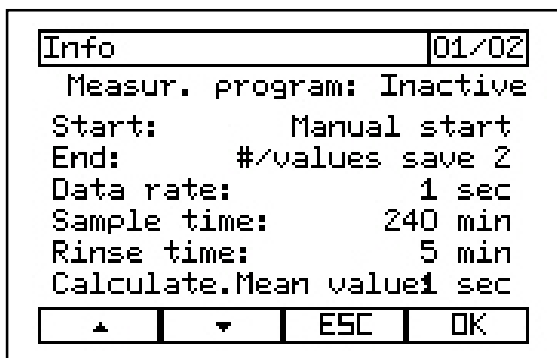

(7) Use the function key or the touch pad to select “OK”

Note:

The program is now pending as

indicated by the  symbol in the status section of the task bar.

(8) Press the Start function key to begin the program.

NOTE:

Analyzer functions such as calibration cannot be accessed if a program is “pending” in the Analyzer Box or Control Unit. An error message will appear “Measuring program – Configuration not possible”.

The program must be deleted to proceed with these functions.

8 Maintenance

For a long lifetime of your testo 350 you should do some simple service procedures. Each analyzer has complete equipment information listed on the bottom.

Bottom view of the Analyzer Box with opened catches:

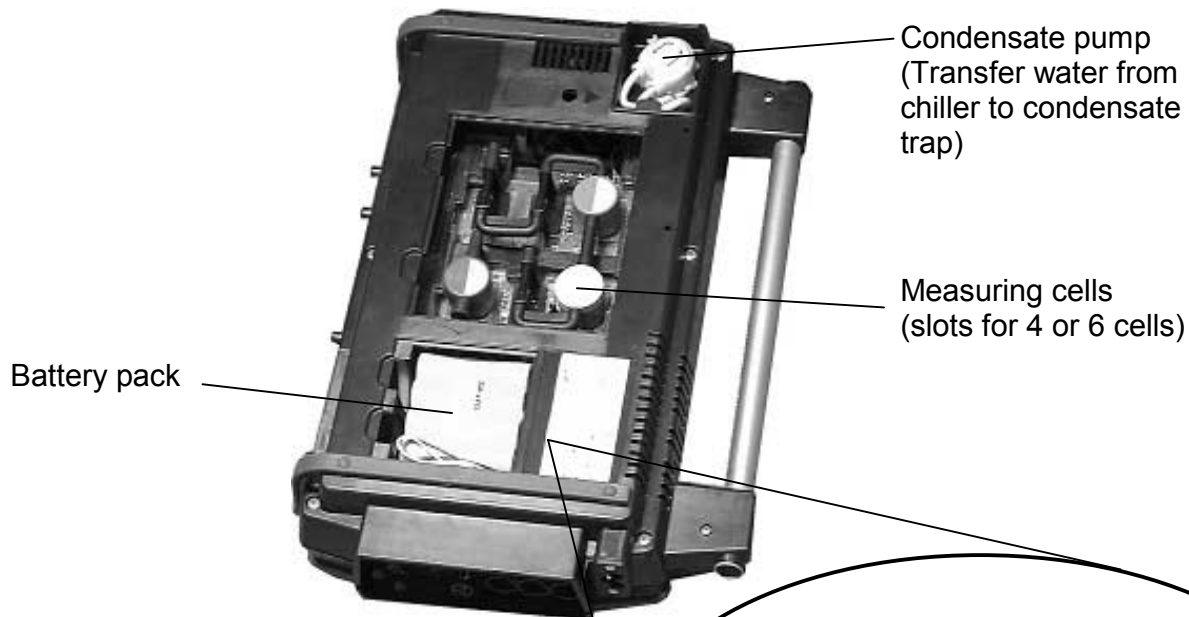

Label of the back shows the type of the installed sensors and other analyzer modules



8.1 Calibration of gas sensors

! CAUTION !

- Observe safety regulation/accident prevention regulations when handling test gases.
- Use test gases in well ventilated room only.

Note:

- Calibration can only be performed with calibration gas of a known composition and concentration. Gas that has exceeded its certification date should not be used.
- For most accurate results, the value of the calibration gas should be between 75% to 125% of expected value. Calibrations below 50% of the expected stack gas concentration are suspect because of multiplication of errors.

Required equipment:

Calibration gas, non-reactive regulators, non-reactive/non-absorbing tubing, a by-pass vent for excess calibration gas, flow regulating needle valve.



! CAUTION !

DO NOT PRESSURIZE THE ANALYZER GREATER THAN 12" H₂O (0.5 PSI) WITH CALIBRATION GAS AS FAULTY READINGS AND DAMAGE MAY OCCUR. USE A BYPASS VENT.

Note:

- Hydrocarbons gas should be in a carrier of O₂ to facilitate calibration.
- Gases like NO₂ and SO₂ should only be used with non-reactive, non-absorbent materials such as stainless steel, Teflon and C-Flex.
- Use single component gases to eliminate and/or identify cross interference.
- Calibration time should not need to exceed 5 minutes per gas exposure to reach stability

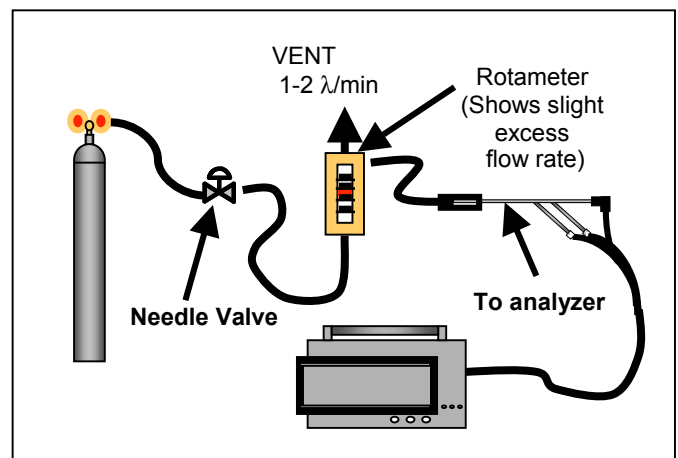
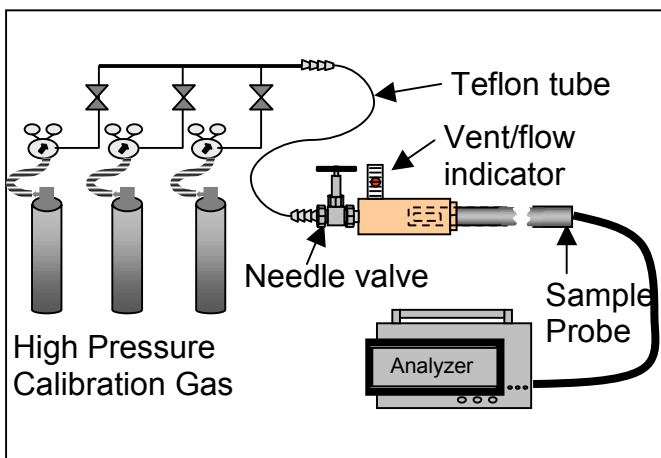

Calibration procedure

Preparation

- (1) Ensure the analyzer is fully charged or operating on AC current
- (2) Ensure the ambient air is free from background gas contaminants.

Warm-up

- (3) Start analyzer and operate pump for 15 minutes to purge residual gases from sensors and to fully achieve operating stability

NOHAME		003 01/02	
71.6	21.00	-----	
Tf	°F O2	% CO2	%
0	0.0	0.0	0.0
CO ppm	NO ppm	NO2 ppm	
Pump	Zero	Air	Zoom

- (4) Zero the analyzer by pressing the function key "Zero" (here the second on the left).

- (5) Press  to enter the menu.

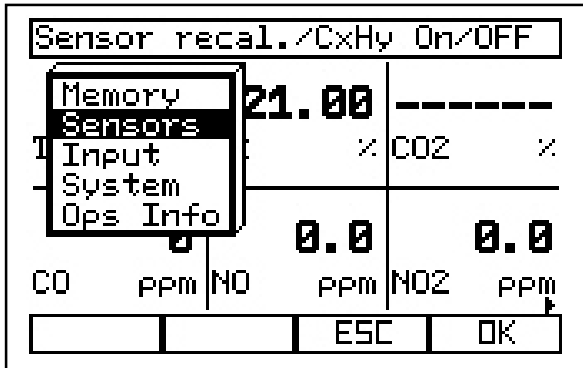

(6) Press to highlight “Sensors” and press .

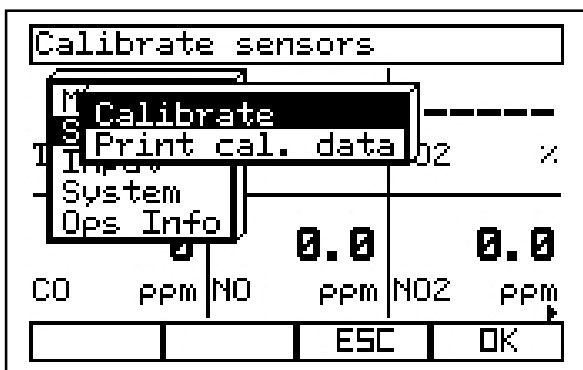

(7) Highlight “Calibrate” and press .

Example: CO Calibration

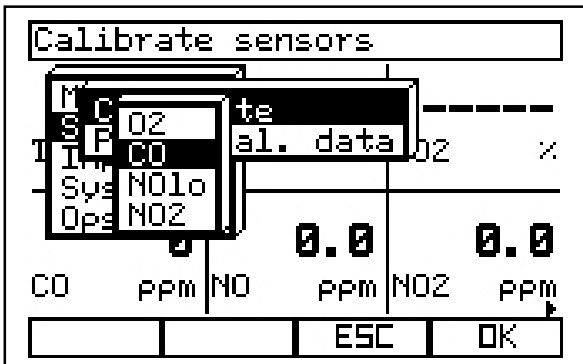

(8) Select the sensor to calibrate with and (here CO) and press to accept.

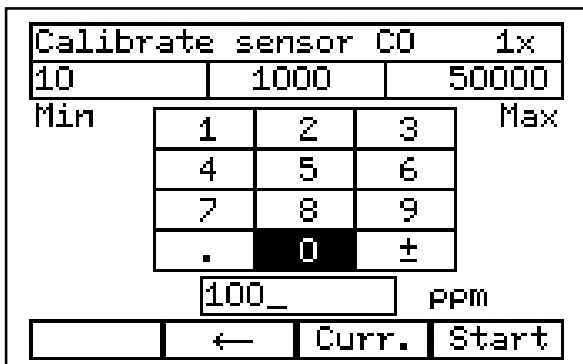

(9) Input the indicated value of the calibration gas (e.g. 100).

Connect to calibration gas

- (10) Connect the sample probe to the calibration apparatus.
- (11) Ensure the needle valve to the calibration gas is closed.
- (12) Press the “Start” function key.

Note:

The total calibration gas flow will be approximately 2 liters/minute. 1 liter/minute to the analyzer; less than 1 liter/minute vented to assure adequate supply.

Adjust gas flow

- (13) Start the flow of the calibration gas to the analyzer by adjusting the needle valve.
- (14) Carefully adjust the flow to provide \approx 1-2 liters/minute flow through the bypass vent.
- (15) When the sensor reading indicates a change, time the process for 3-5 minutes

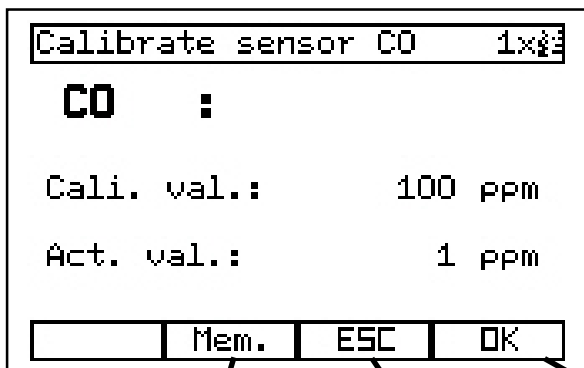

(16) During the calibration this screen appears and shows the values.

Note:

Memory will save the values but not calibrate (adjust) the sensor.

Escape will not calibrate (adjust) the sensor.

Accept values
At the end of the 3-5 minutes, press the “OK” function key to adjust the sensor and to save the values into the memory.

Prepare to calibrate other sensors

- (17) Purge the analyzer on fresh air for 5 minutes before beginning the next gas

Printing calibration data

Note:

If there is no calibration data in the sensor (e.g. sensors with a manufacturing date before January 2003) dashes are printed instead of the target and actual values. Only the serial number and date of adjustment are printed.

8.2 Changing batteries in the Analyzer Box



- (1) Disengage catch
- (2) Remove battery pack and pull plug from socket after disengaging
- (3) Insert new battery pack, ensure that the plug engages.
- (4) Put on and close cover

8.3 Changing batteries in the Control Unit



- (1) Disengage catch
- (2) Remove batteries
- (3) Insert new batteries
- (4) Ensure that the batteries are inserted the right way (+ to +)
- (5) Put on and close cover

8.4 Change printer paper



- (1) Switch on the device
- (2) Assign the line feed to the function key **Lfeed**
- (3) Open the printer cover
- (4) Insert paper
- (5) Draw in the paper by pressing **Lfeed**
- (6) Place the paper roll in the cover and close it

8.5 Changing filters

If the filters are visibly dirty, they need to be changed or replaced. If the pump performance drops audibly or you see a drop in the pump rate display, the filters should be checked and replaced if necessary. In most cases, it is sufficient to only replace the flue gas filter.



- (1) To replace a filter, remove the filter cover by twisting to the left
- (2) Take out the used filter and insert the new filter
- (3) Ensure that the o-ring is still in place.
- (4) Screw on the filter cover
- (5) The cross strut of the filter housing must be aligned with the markings on the housing of the measuring unit

8.6 Remove condensate water



To drain the water, remove the cap. You can also install a tube over the nipple for water drainage.

8.7 Changing measurement sensors

If an error message occurs that a measurement sensor is “spent” you have to replace that sensor. The analyzer may do further measurements but you will not get a value of the spent sensor (i.e. O_2) and the calculated values relates to it (i.e. efficiency, excess air).



To change sensors, open cover the on the rear of the Analyzer Box.

8.7 Changing measurement sensors

The measuring cells come with a personalized circuit board on which sensor data are stored. After the new sensor is installed, calibration is not necessary because the circuit board contains all necessary information.



- (1) Switch off the unit and isolate from the power.
- (2) Open the large cover on the rear of the analyzer box.
- (3) Remove the black plastic, outer cover sensor heater bar.



- (4) Pull the hose connections from the used sensor.
- (5) Insert and connect a new measuring sensor. Make sure the tab and cars on the side of the sensor align with the tabs in the sensor slot.
- (6) Push on the measuring cell heater.

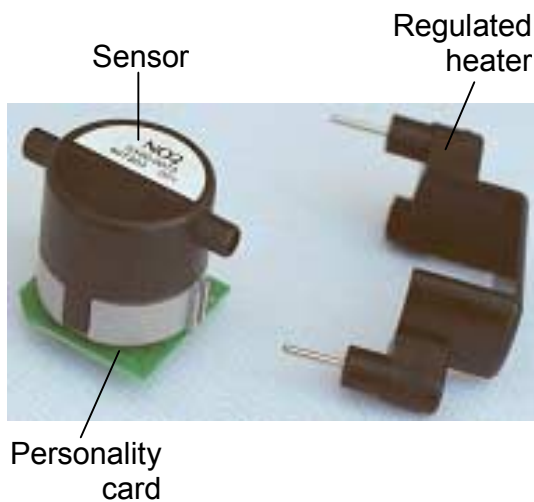

Note:

The O₂ measuring cell requires a compensation period of approx. 60 min. after replacement in the testo 350. The unit must be plugged into AC power, but not be switched on during this time.

When clipping the heating bar onto the CO measuring cell, ensure that the temperature sensor (orange bead) is covered by the sensor heater cap.

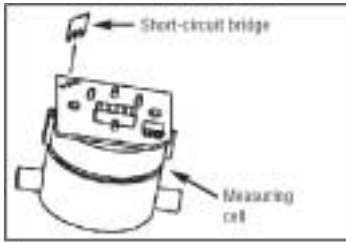

Installing CO-/NO₂-/SO₂-/H₂S measuring cell

! Caution !
Remove the short-circuit bridge when installing a new measuring cell.

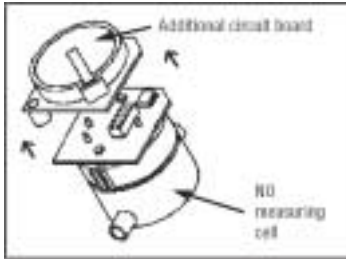

Installing NO measuring cell

! Caution !
Remove the auxiliary circuit board before installing the NO cell.
Pull the additional circuit board from the NO cell (see drawing).

8.8 Condensate pump service

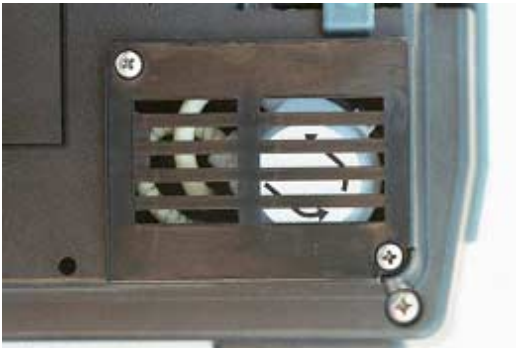

- 1) Empty the condensate-collecting vessel
- 2) Remove the cover



- 3) Disengage and pull off the pump cassette
- 4) Remove the bend protection spring and push onto the hose at the suction side of the new pump cassette.
- 5) Push on the hose (see illustration)
- 6) Ensure that the hoses are not trapped or constrained
- 7) Push the replacement cassette onto the motor shaft until it engages
- 8) Attach cover.



9 Appendix

9.1 Function key list

Note:

Function key labels indicate what *will happen* if you push the button, not what is currently active.

Key	Analyzer Box Function Key Description
<input type="checkbox"/>	Free, unassigned function key
Zoom	Magnified display of the readings (3 readings on one display screen [magnified] or 6 readings [standard]).
Pump	Starts the gas pump. Status bar shows blinking bull's eye.
PStop	When Pump is pressed, the function key changes to PStop (pump stop), pump stops and the readings are static on the display.
v On	Switches on and zeros velocity measurement. To use with pitot tube.
Mem.	Memory. Manually store the current values into the displayed location name.
DeltaT	Use of the two temperature inputs of the Analyzer Box as separate 2-channel temperature measurement with dT display
DeltaP	Activates the separate differential pressure measurement in the Analyzer Box.
Start/ No prog	Starts a previously programmed measuring program.
Print	Prints all displayed readings.
Lfeed	Printer line feed.
Zero	Initiates fresh air and zeroing phase (1 minute). The Analyzer Box draws fresh air through the measurement gas inlet or the fresh air valve (if fitted).
Gas/Air	Manually change internal valve from probe to fresh air port.
CO off	Deactivation CO sensor and purge with fresh air.
CO on	Activate CO sensor in the gas path.
HC on/off	Turn Hydrocarbons (CxHy) sensor on and off.
1/X	Change the CO dilution factor in steps from 1/X up to 40/X
Control Unit Function Key Description	
Zoom	Zoom readings
Hold	Hold current value
Max	Display max. values since switching on
Min	Display min. values since switching on
Mean	Calculate average
Vol	Activate velocity measurement (with a velocity or differential pressure probe or integrated differential pressure probe)
Veloc.	Activate/deactivate velocity (with external differential pressure probe or for the integrated differential pressure probe)
dP 1	Measuring range 16" H ₂ O for integrated differential pressure probe
dP 2	Measuring range 80" H ₂ O for integrated differential pressure probe
P=0	Zero pressure probe
ppm=0	Zero the CO probe
Start/Stop	Start/stop measuring program
Search	Determine system configuration
Mem.	Save the readings
Print	Print the readings
Lfeed	Printer line feed
aw	Water activity

9.2 Screen display parameters

Testo 350 XL - Available Screen Parameters	
Parameter	Definition
O ₂	oxygen 0 - 25%
CO	* carbon monoxide (0 - 10,000 ppm)
CO _{low}	* carbon monoxide (0 - 500 ppm, low-range sensor)
NO	* nitrogen monoxide (0 - 3000 ppm)
NO _{low}	* nitrogen monoxide (0 - 300 ppm, low-range sensor)
NO ₂	* nitrogen dioxide (0 - 500 ppm)
SO ₂	* sulfur dioxide (0 - 5000 ppm)
CxHy	* total hydrocarbons (0 - 4%)
H ₂ S	* hydrogen sulfide (0 - 300 ppm)
H ₂	hydrogen
NOx	nitrogen oxides (NO + NO ₂)
Tf	temperature flue (stack temperature)
Ta	temperature of ambient air / temp of 2nd probe socket
Delta T	temperature difference
T1	temperature of primary air
T2	temperature of secondary air
Eff.	combustion efficiency
CO ₂	carbon dioxide (calculated %)
ExA	excess air
dCO	undiluted CO (in relation to O ₂ %)
Htt	heat transfer temperature
O ₂ ref	oxygen reference value
CO ₂ m	theoretical CO ₂ maximum for selected fuel
delta P	pressure difference
Drft	draft in stack (psi or "H ₂ O)
batt	battery charge (volts)
Tana	temperature of analyzer
Op.h.	operating hours on analyzer
Pump	pump flow rate through analyzer
cNO	corrected NO (according to O ₂ ref.)
cCO	corrected CO (according to O ₂ ref.)
cSOx	corrected SOx (according to O ₂ ref.)
cNOx	corrected NOx (according to O ₂ ref.)
Vel	stack gas velocity in feet/min (pitot tube)
FLOW	flow in cfm (vane anemometer, hot wire)
tdew	temperature dew point
mCO	mass CO (lbs/hr, ton/yr)
mSO ₂	mass CO (lbs/hr, ton/yr)
mNOx	mass CO (lbs/hr, ton/yr)
Fuel	fuel selected (used for calculations)

* Items marked with symbol will only display if installed in analyzer



9.3 Menu structure for Control Unit

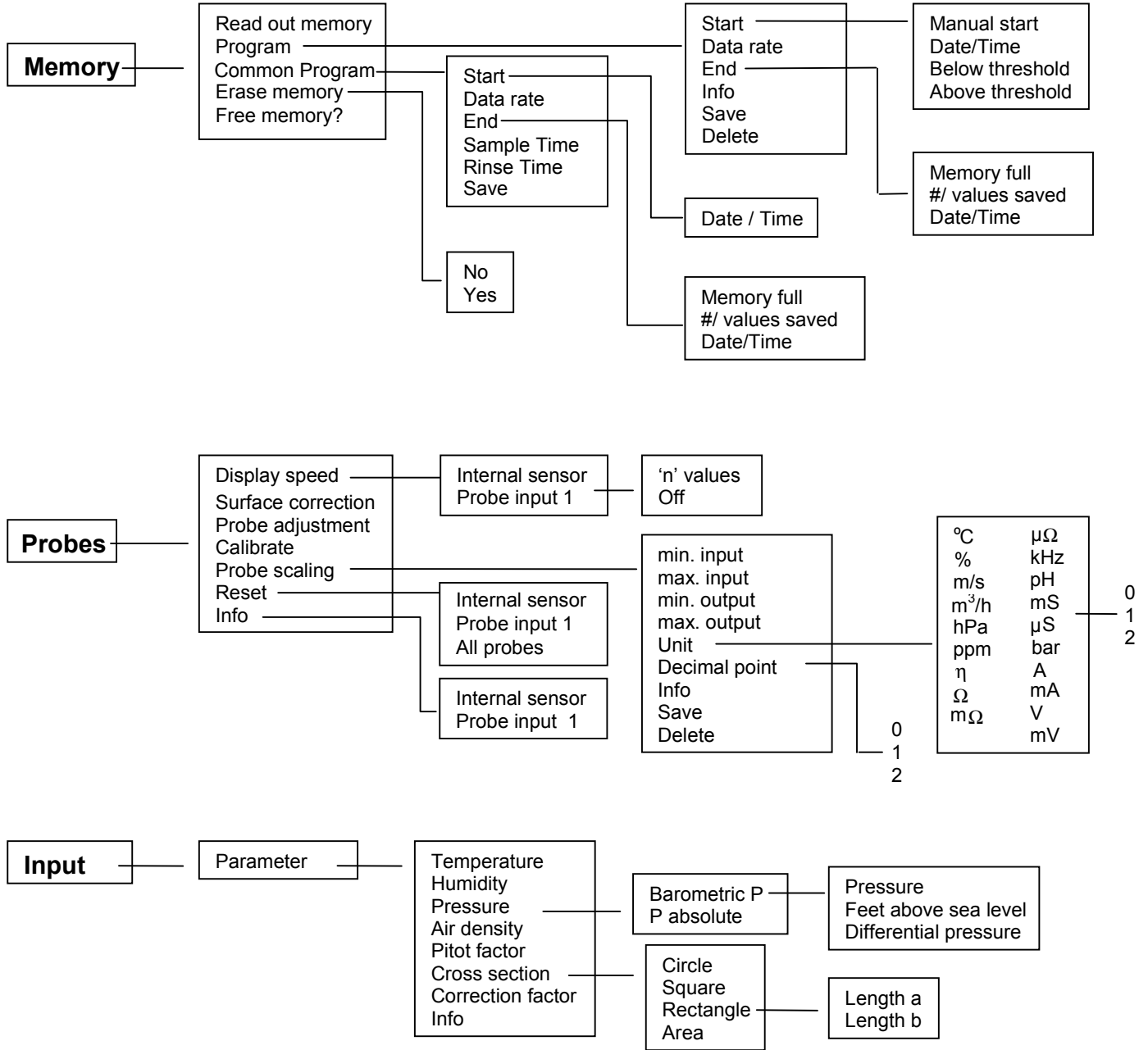

(Continue) Menu structure for Control Unit

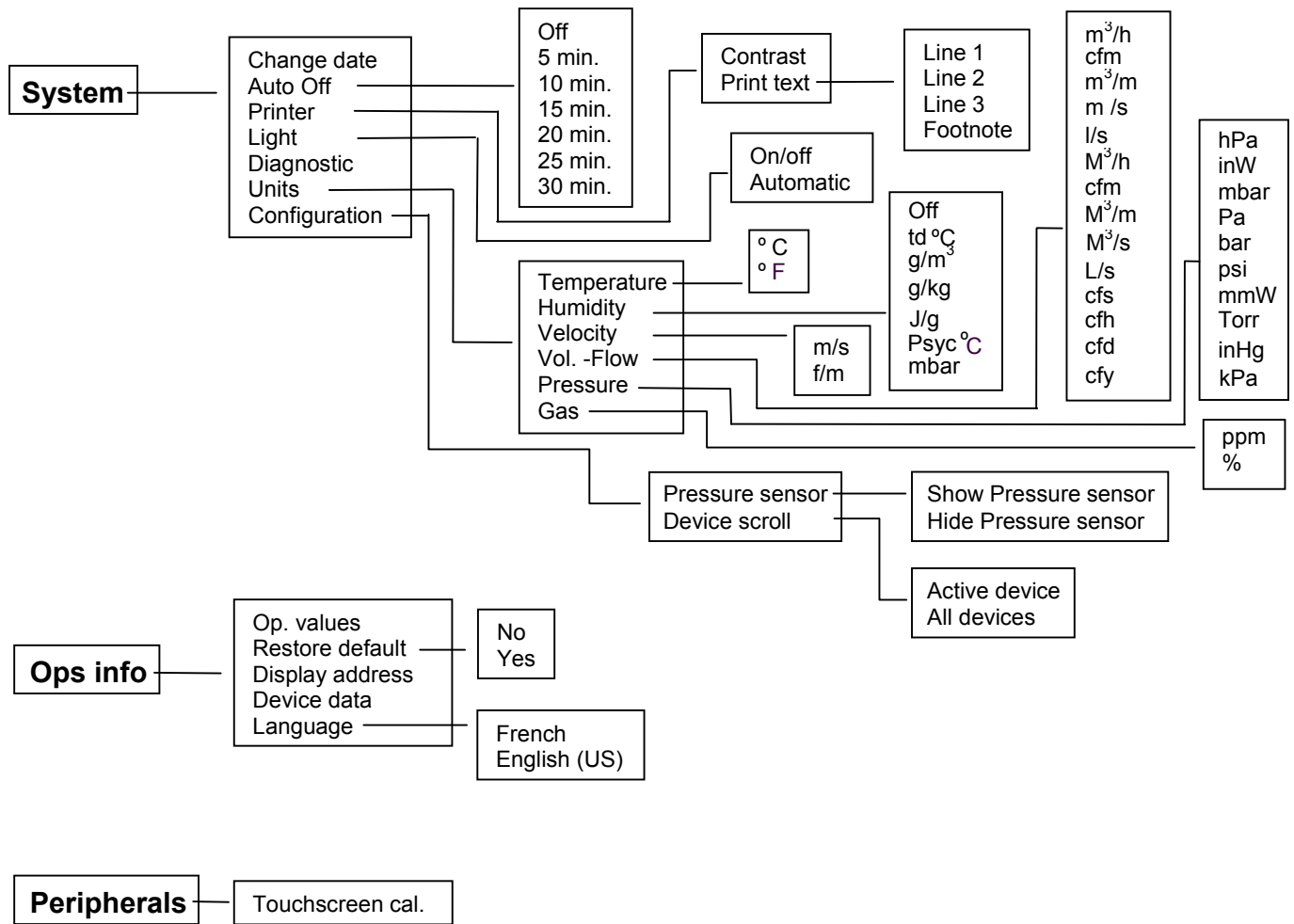



9.4 Menu structure for Analyzer Box

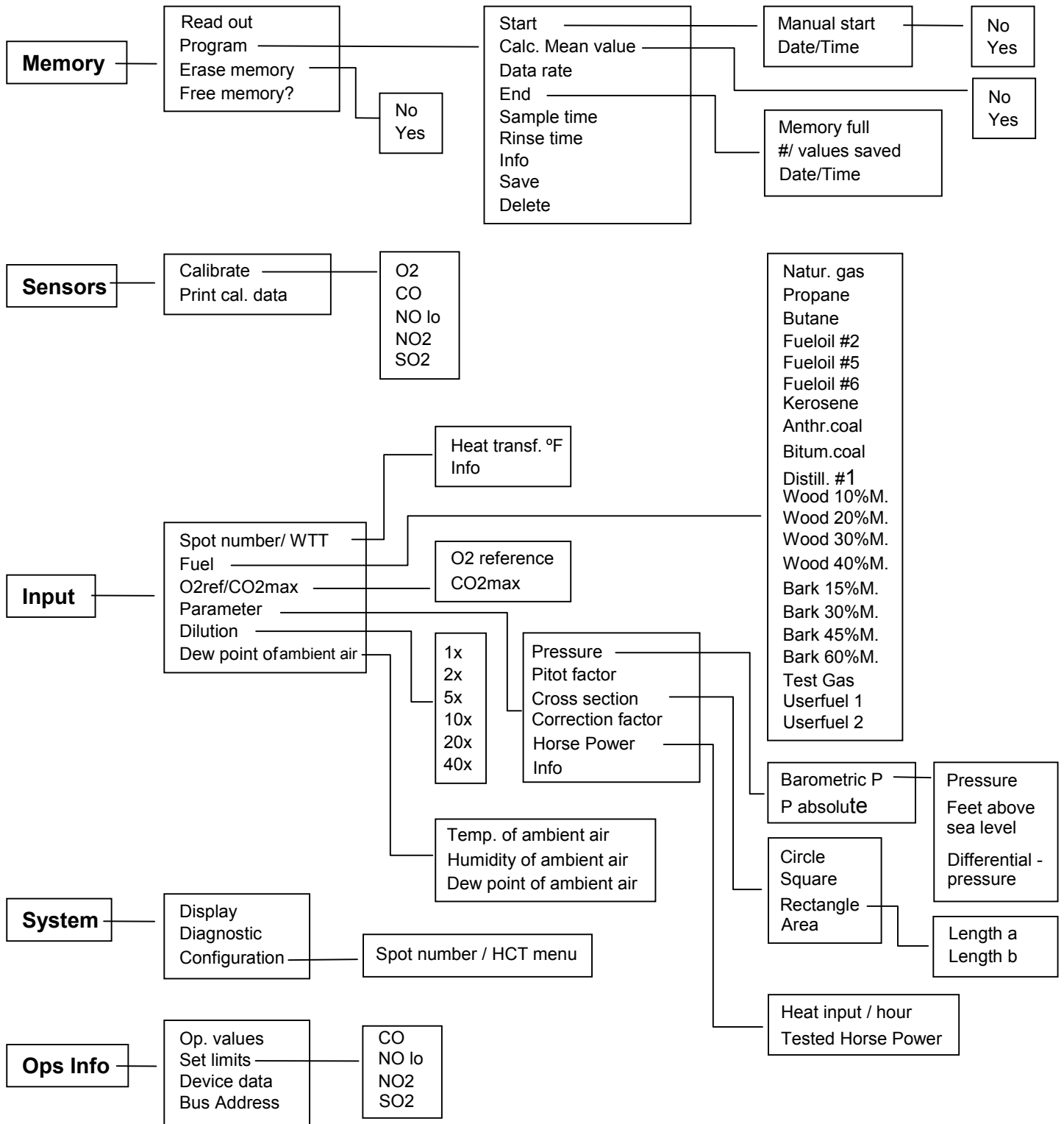

9.5 Sample measuring and rinsing cycle times

Suggested measuring and rinsing cycles for toxic EC sensors for long-term measurements and maximum sensor survivability

Sensor	Gas concentration (PPM)	Measurement <i>min</i>	Rinse <i>min</i>
COH ₂	50	60	5
	100	30	5
	200	20	10
	500	10	10
	1,000	10	15
	2,000	10	20
	4,000	5	30
	8,000	5	45
	10,000	5	60
COH ₂ low	10	60	5
	20	30	5
	50	20	10
	100	10	10
	200	10	15
NO	50	60	5
	100	45	5
	200	30	5
	500	20	10
	1,000	10	10
	2,000	10	20
	3,000	5	30
NOlow	10	60	5
	20	45	5
	50	30	5
	100	20	10
	200	10	10
	300	10	20
NO ₂	10	60	5
	20	45	5
	50	30	5
	100	20	10
	200	10	10
	500	10	20
SO ₂	50	60	5
	100	30	5
	200	20	10
	500	15	10
	1,000	10	10
	2,000	10	20
	5,000	5	40
H ₂ S	10	40	5
	20	30	5
	50	20	10
	100	10	10
	200	5	10
	300	5	20

9.6 CO-Measuring ranges with different dilution steps

Note:

If the ambient air contains interfering gases, push the hose onto the dilution inlet () next to the Trigger Input and place in a clean atmosphere.

Possible dilution factors	
Dilution factor	Ratio of diluting gas : measured gas
1	no dilution
2	1 : 1
5	4 : 1
10	9 : 1
20	19 : 1
40	39 : 1

Our recommended dilution factors when testing:			
Dilution factor	CO concentration in flue gas with CO _{standard}	Dilution factor	CO concentration in flue gas with CO _{low}
1	0 to 500	1	0 to 100
2	300 to 2,000	2	50 to 500
5	500 to 10,000	5	250 to 1,500
10	1,500 to 20,000	10	400 to 3,000
20	3,000 to 80,000	20	1,000 to 6,000
40	6,000 to 400,000	40	2,000 to 20,000

Technical data:				
Dilution factor	Measuring range with CO _{standard}	Resolution	Measuring range with CO _{low}	Resolution
0	0 to 10,000 ppm	1 ppm	0 to 500 ppm	0.1 ppm
2	0 to 20,000 ppm	2 ppm	300 to 2,000 ppm	0.2 ppm
5	0 to 50,000 ppm	5 ppm	500 to 10,000 ppm	0.5 ppm
10	0 to 100,000 ppm	10 ppm	1,500 to 20,000 ppm	1 ppm
20	0 to 200,000 ppm	20 ppm	3,000 to 80,000 ppm	2 ppm
40	0 to 400,000 ppm	40 ppm	6,000 to 400,000 ppm	4 ppm

Examples of when to use the dilution system:

- when combustion source is “out of tune” or improperly controlled
- in reduced burner atmosphere
- adjustment of industrial burners (from high to low CO...)
- optimization and tuning of gas turbines
- engine measurement at high H₂ levels (controlled motors)
- during long-term measurements to keep a low load on the CO sensor

9.7 Error codes/diagnostics

Error messages		Cause	Remedy
NO value drifts		Loss of aux. voltage for NO	Measurement only after 2 hours
Double module		Measuring module already installed	Install correct sensor
Dilution		Gas flow rate in dilution path too high/too low	Check for overpressure and obstructions at dilution inlet
O ₂	Cell spent	Value above 20.9%	Switch unit off/on
	Signal too high		Replace O ₂ cell
CO	Switch-off	Cell drifts excessively	Replace cell if necessary
NO	Signal unstable	Signal not at zero	Fresh air until regenerated
NO ₂	Signal too high	Value above selected shut-off threshold	Activate "Air" cycle to regenerate sensor
SO ₂			
H ₂ S			
Battery low		Insufficient power reserves	Connect instrument to the AC power outlet
Unit temperature		Unit temperature is outside the operating temperature	If low, permit analyzer to warm up. If too hot, operate within limits.
Cell temperature too high		Cell temperature outside specifications	Operate analyzer within temperature limits
Pump flow rate		Too low/too high. Gas flow rate	Check pump / gas path / filter / probe connection
Gas conditioning system		Gas cooler / Peltier cooler not working	Purge with air, ckeck filters (replace them when necessary), check the condensate trap and then call for service
Peltier temp. Invalid parameter			
Probe failure or probe not connected		Temperature probe not connected or thermocouple damaged	Connect temperature probe or exchange thermocouple
Ambient air temperature saved		No AT probe connected. The measured temperature of the flue gas probe is saved as an ambient air temperature.	- Do nothing, or - insert ambient air probe
Configuration not possible		Refers to a saved program. For example, end criteria is invalid because starting criteria was changed	Delete program in Analyzer Box and Control Unit
Note: bus supply is switched off		If the internal voltage is too low, the bus supply power is turned off (protection for internal battery/rech. battery).	Attach additional bus power supply unit
Information that participant was cut off from the bus		Instrument was cut off from bus, e.g. by pulling out BUS plug or the power supply is too low.	Check plug-in connections or recharge battery units power supplies

9.8 Status and error indicators

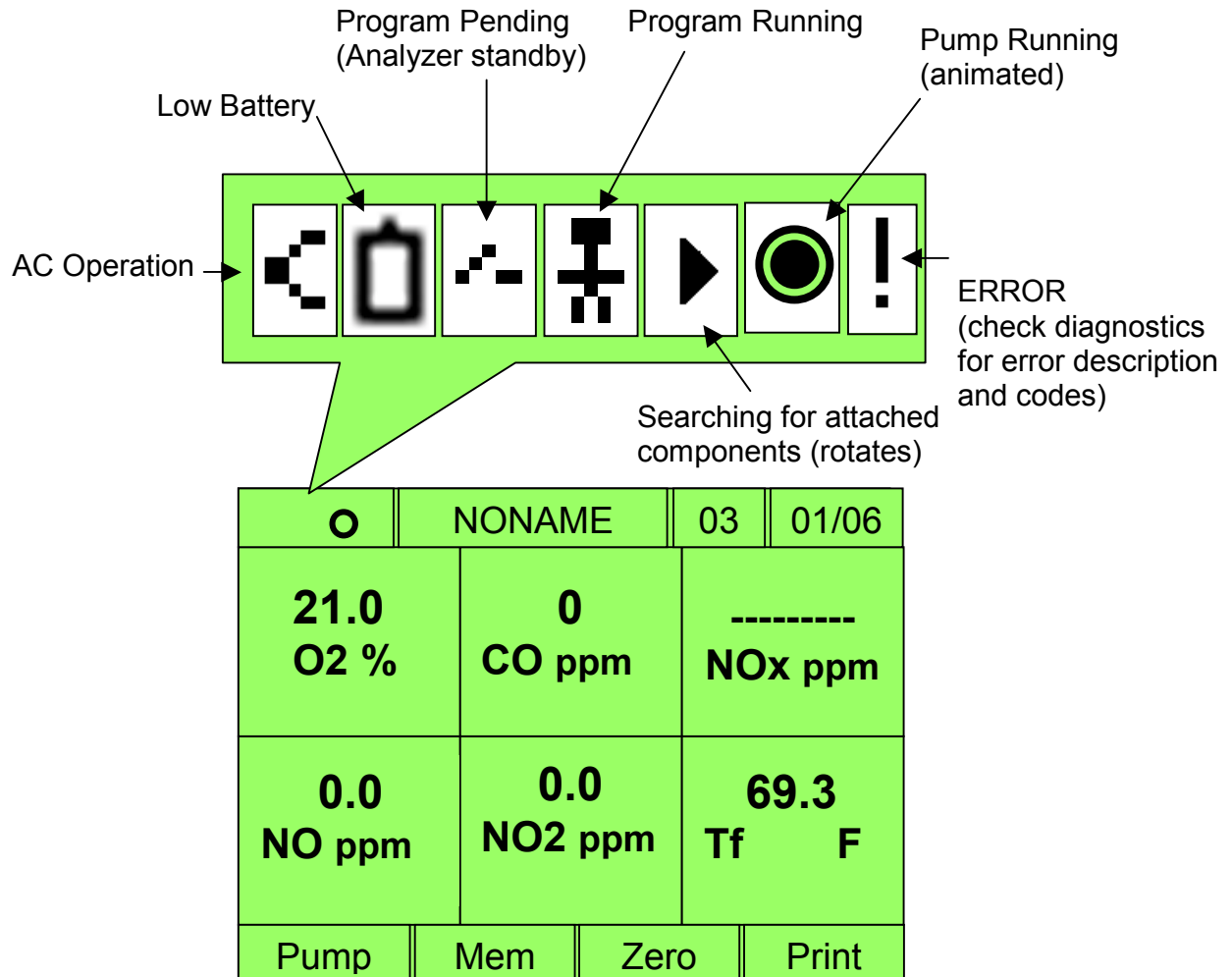

Note:

- Batteries do not charge when analyzer is operating.
- Program pending errors – may need to also look for a program pending in the Control Unit.

9.9 Principles of calculations

Units conversions

%		
Unit	Resolution	Description of formula
%	0,1 0,01	$x[\%] = \frac{x[ppm]}{10000}$

O ₂ reference (cCO,cNOx,...)		
Unit	Resolution	Description of formula
ppm _b	1	$x[ppm_b] = x[ppm] \cdot \frac{20,94 - O_{2\ ref}}{20,94 - O_2}$

lbs/mBTU		
Unit	Resolution	Description of formula
$\left[\frac{lbs}{mBTU} \right]$	1	$x\left[\frac{lbs}{mBTU} \right] = x[ppm] \cdot \rho_{Gas} \cdot \frac{20,94}{20,94 - O_2} \cdot \frac{FBr}{430.0269}$

lbs/mBTU _b based on O ₂ reference (cCO,cNOx,...)		
Unit	Resolution	Description of formula
$\left[\frac{lbs}{mBTU} \right]$	1	$x\left[\frac{lbs}{mBTU} \right] = x[ppm] \cdot \rho_{Gas} \cdot \frac{20,94 - O_{2\ ref}}{20,94 - O_2} \cdot \frac{FBrGas}{430.0269}$

Grams per horse power/hour (CO, NOx)			
Parameter	Unit	Resolution	Description of formula
CO,NOx	G/hp	0.1 %	see below
<p>Setting parameter (via operating device =Control Unit): Heat input /hour: default 10 (Range 10...9999998) Tested Horsepower: default 10 (Range 10...50000)</p> <p>Pounds per hour:</p> $lbpH \left[\frac{lb}{h} \right] = \rho_{Gas} \cdot \frac{20,94}{20,94 - O_2} \cdot \frac{FBrGas}{430,0269} \cdot HeatInputPerHour$ <p>FBrGas = fuel dependent, as parameter enterable, ρ Gas (standard density) CO = 1,25 kg/m³ / NOx = 2,05 kg/m³</p> <p>Grams Per Horsepower-Hour:</p> $gHPH = \frac{lbpH[CO / NOx] \cdot 453,6}{Tested - Horsepower}$			



Calculations

CO ₂			
Parameter	Unit	Resolution	Discription of formula
CO 2	%	0.01 %	$CO_2 = CO_{2 \max} \cdot \frac{20,94\% - O_2[\%]}{20,94\%}$

The constans CO_{2 max} are fuel specific and are listed in the table below

Flue gas loss "loss"			
Parameter	Unit	Resolution	Discription of formula
loss	%	0.1 %	see below
$loss[\%] = \left(\frac{A}{20,94\% - O_2[\%]} + B \right) \cdot (FT - AT) + C$			
<p>A, B, C: fuel specific factors, for values see table below FT: flue gas temperature AT: ambient temperature</p>			

Combustion Efficiency "Eff"			
Parameter	Unit	Resolution	Discription of formula
loss	%	0.1 %	$Eff[\%] = 100 - loss[\%]$

if loss is negative, Eff becomes greater than 100 %

Fuel values for USA and its formula number for the diversion into Eff:							
USA	CO _{2max}	O _{2ref}	A	B	C	F _{Br}	Smoke spot no.
natur. gas	11,7	3,0	0,5910	0,0011	9,66	0,2182	no
propane	15,12	3,0	0,5970	0,0013	8,00	0,2182	no
butane	14,1	3,0	0,6000	0,0013	7,68	0,2182	no
fueloil #2	15,70	3,0	0,6395	0,0016	6,15	0,2302	no
fueloil #5	16,3	3,0	0,6265	0,0021	5,24	0,2302	no
fueloil #6	16,7	3,0	0,6375	0,0018	4,85	0,2302	no
kerosene	15,12	3,0	0,6160	0,0015	6,63	0,2302	no
anthr. coal	19,90	7,0	0,6970	0,0027	2,21	0,2505	no
bitum. coal	18,50	7,0	0,6725	0,0024	3,58	0,2450	no
distill. #1	15,40	3,0	0,6300	0,0018	6,45	0,2332	no
wood 10% m.	20,0	7,0	0,6175	0,0025	8,14	0,2314	no
wood 20% m.	20,0	7,0	0,6200	0,0025	9,23	0,2314	no
wood 30% m.	20,0	7,0	0,6200	0,0025	10,43	0,2314	no
wood 40% m.	20,0	7,0	0,6190	0,0025	11,63	0,2314	no
bark 15% m.	20,0	7,0	0,6655	0,0028	7,88	0,2404	no
bark 30% m.	20,0	7,0	0,6655	0,0028	9,71	0,2404	no
bark 45% m.	20,0	7,0	0,6655	0,0027	11,55	0,2404	no
bark 60% m.	20,0	7,0	0,6655	0,0027	13,40	0,2404	no
test gas	0,0	0,0	0,0	0,0	0,0	0,0	no
userfuel 1;2	0,0	0,0	0,0	0,0	0,0	0,0	no

Dew point "T _{dew} "			
Parameter	Unit	Resolution	Discription of formula
T _{dew}	°C/°F	0,1 °C	see below
$T_{pAG} = - \frac{\ln\left(\frac{F_{H2O} \cdot P_{Abs}}{610.78}\right) \cdot 234.175}{\ln\left(\frac{F_{H2O} \cdot P_{Abs}}{610.78}\right) - 17.08085}$			
<p>T_{pAG}: Dew point temperature of flue gas F_{H2O}: Fuel dependent steam factor (Vol %) P_{Abs}: absolute pressure in mbar</p> <p>Hint: Is the dew point temperature is higher than AT, AT is displayed.</p>			

Excess Air „ExA“			
Parameter	Unit	Resolution	Discription of formula
ExA	%	0.1 %	see below
$\lambda = ExcessAir = 100 \cdot \frac{O_2 - \frac{CO}{2}}{0,2682 \cdot (100 - O_2 - CO_2 - CO) - \left(O_2 - \frac{CO}{2}\right)}$			
<p>Hint: O₂, CO, CO₂ in %</p>			

Flow velocity "Vel"			
Parameter	Unit	Resolution	Discription of formula
vel	m/s	0,01	see below
$V \left[\frac{m}{s} \right] = \sqrt{\frac{741,9 \cdot \Delta p \cdot (FT + 273.15)}{\rho \cdot p_{Ort}}} \cdot \alpha$			
<p>The calculation for the gas density ρ depends on the concentration, only O₂ und CO₂ will be considered:</p> $\rho \left[\frac{kg}{m^3} \right] = (O_2 \cdot 0,0143 + CO_2 \cdot 0,0197 + (100 - O_2 - CO_2) \cdot 0,0125) \cdot (100 - F_{H2O}) / 100 + F_{H2O} \cdot 0,00833$			
<p>F_{H2O}: fuel dependent steam factor (Vol %) O₂, CO₂ in Vol% P_{Ort}: costumary absolut pressure in mbar Δp: measured differential pressure in mbar AT: measured fluegas temperature (velocity temperature) in °C α: entered pitot tube coefficient in the range from 0.00 to 1.50 FT: Fuel temperature</p>			



Volume flow "FLOW"		
Unit	Resolution	Discription of formula
m ³ /s	1 m ³ /s	see below
$V \left[\frac{m^3}{s} \right] = v \left[\frac{m}{s} \right] \cdot A [cm^2] \cdot \frac{m^2}{cm^2 \cdot 10000}$		
<p>A: calculated surface consisting of entered coefficients A1 and A2 in cm V: calculated volume flow in m³/s</p>		

Mass flow "m _{xxx} "													
Parameter	Unit	Resolution	Discription of formula										
m _{xxx}	kg/h	1kg/h	see below										
$M = x [ppm] \cdot \left(\frac{100 - F_{H_2O}}{100} \right) \cdot \rho_{Gas} \cdot V \cdot \frac{273,15 \cdot P_{abs}}{(273,15 + FT) \cdot 1013,0} \cdot 10^{-6} \cdot 3600$													
<p>F_{H2O}: fuel dependent steam factor (Vol %) ρ_{Gas}: standard density of gas to be measured</p> <table style="margin-left: 40px;"> <tr><td>CO:</td><td>1,25 kg/m³</td></tr> <tr><td>NO_x:</td><td>2,05 kg/m³</td></tr> <tr><td>SO₂:</td><td>2,858 kg/m³</td></tr> <tr><td>H₂S:</td><td>1,54 kg/m³</td></tr> <tr><td>CO₂:</td><td>1,963 kg/m³</td></tr> </table>				CO:	1,25 kg/m ³	NO _x :	2,05 kg/m ³	SO ₂ :	2,858 kg/m ³	H ₂ S:	1,54 kg/m ³	CO ₂ :	1,963 kg/m ³
CO:	1,25 kg/m ³												
NO _x :	2,05 kg/m ³												
SO ₂ :	2,858 kg/m ³												
H ₂ S:	1,54 kg/m ³												
CO ₂ :	1,963 kg/m ³												
<div style="border: 1px solid black; padding: 5px; display: inline-block;"> <p>1 kg/h = 2,205 lb/h 1 lb/h = 0,4536 kg/h</p> </div>													
<p>V: calculated volume flow in m³/s P_{abs}: absolut pressure in mbar FT: fluegas temperature</p>													

9.10 Technical data

Probe type	Temperature	O ₂	CO (H ₂ compensated)	COlow	CO ₂	NO	NOlow
Measuring range	-40... +2192 °F	0... +25 Vol.% O ₂	0... +10000 ppm CO	0... +500 ppm CO	0... CO ₂ max Vol. % CO ₂	0... +3000 ppm NO	0... +300 ppm NO
Accuracy ± 1 digit	<33 °F (-40... +212 °F) <0.5% m.v. (+212...+2192 °F)	±0.8% of f.v. (0...+25 Vol.%O ₂)	±5% of mv (+100...+2000 ppm CO) ±10% of mv (+2001...+10000 ppm CO) ±10 ppm CO (0...+99 ppm CO)	±5% of mv (+40...+500 ppm CO) ±2 ppm CO (0...+39.9 ppm CO)	Calculated from O ₂	±5% of mv (+100...+1999.9 ppm NO) ±10% of mv (+2000... +3000 ppm NO) ±5 ppm NO (0...+99 ppm NO)	±5% of mv (+40... +300 ppm NO) ±2 ppm NO (0...+39.9 ppm NO)
Resolution		0.1 Vol.% (0... +25 Vol. O ₂)	1 ppm CO (0...+10000 ppm CO)	0.1 ppm CO (0...+500 ppm CO)	0.01 Vol. % CO ₂	1 ppm NO (0...+3000 ppm NO)	0.1 ppm NO (0...+300 ppm NO)
Reaction time		20 s	40 s	40 s	20 s	30 s	30 s
Reaction type		t95	t90	t90	t95	t90	t90
Probe type	NO ₂	SO ₂	Efficiency	Flue gas loss	Differential pressure 1	Differential pressure 2	Flow Velocity
Measuring range	0... +500 ppm NO ₂	0... +5000 ppm SO ₂	0... +120 %	-20... +99.9 % qA	± 80" H ₂ O	± 16" H ₂ O	0... 7900 ft/min
Accuracy ± 1 digit	±5% of mv (+100... +500 ppm NO ₂) ±5 ppm NO ₂ (0...+99.9 ppm NO ₂)	±5% of mv (+100...+2000 ppm SO ₂) ±10% of mv (+2001...+5000 ppm SO ₂) ±5 ppm SO ₂ (0...+99 ppm SO ₂)			<1% of m.v. (-20"...-80" H ₂ O) <1% of m.v. (+20"...+80" H ₂ O) <0.5% (-19"...+19" H ₂ O)	<1% of m.v. (-16"...1.2" H ₂ O) <1% of m.v. (+16"...+1.2" H ₂ O) <0.5% (-1.2"...+1.2" H ₂ O)	
Resolution	0.1 ppm NO ₂ (0... +500 ppm NO ₂)	1 ppm SO ₂ (0...+5000 ppm SO ₂)	0.1 % (0... +120 %)	0.1 % qA (-20...+99.9 % qA)	0.01" H ₂ O	0.01" H ₂ O	10 ft/min
Reaction time	40 s	30 s					
Reaction type	t90	t90					

Dimensions 16"x11"x4"
Weight: 9 lbs
Storage temp.: -4... +122 °F
Oper. temp.: +20... +113 °F
Material/Housing: ABS

Additional technical data:
 Memory: 250 000 readings
 Power supply: Via integrated mains unit (90 V to 260 V, 47 to 63 Hz)
 or exchangeable rechargeable batteries
 Electrical power required:
 0.5 A (110 V AC), 0.3 A (230 V AC)
 Dew point calculation: +32 to +210 °F td
 Maximum positive pressure: 20" H₂O
 Maximum negative pressure: 80" H₂O
 Pump flow: 0.8 m/s with flow monitoring
 Max. dust load: 20 g/m³ dust in flue gas
 Max. humidity load: +158 °F
 Dew point temperature at inlet

Additional technical data:
 Event trigger socket: 5 to 12 V (ascending or descending edge)

Measuring range extension (dilution) for CO:
 Dilution factors: 0, 2, 5, 10, 20, 40
 Dilution gas: Fresh air or N₂
 Accuracy: Reading plus max. 2%
 Trigger input testo 350XL:
 Voltage: 5 to 12 volt
 (rising or falling edge)
 Pulse width > 1 second
 Load: 5 V/max. 5 mA, 12 V/max. 40 mA

Additional technical data only for testo 350XL analysis box	
Probe type	H ₂ S measurement
Meas. range	0... +300 ppm
Accuracy	±5% of mv (+40...+300 ppm) ± 1 digit ±2 ppm (0...+39.9 ppm)
Resolution	0.1 ppm (0...+300 ppm)
Reaction time	35 s
Reaction type	t90

Technical data for HC module			
Parameter	Methane	Propane	Butane
Measuring range ¹	100 to 40,000 ppm	100 to 21,000 ppm	100 to 18,000 ppm
Accuracy	Less than 400 ppm (100 to 4000 ppm)/Less than 10 % of reading (greater than 4000 ppm)	Less than 400 ppm (100 to 4000 ppm)/Less than 10 % of reading (greater than 4000 ppm)	Less than 400 ppm (100 to 4000 ppm)/Less than 10 % of reading (greater than 4000 ppm)
Resolution	10 ppm	10 ppm	10 ppm
Min. O ₂ requirement in flue gas	2% + (2 x methane reading)	2% + (5 x propane reading)	2% + (6.5 x butane reading)
Response time t90	Less than 40 s	Less than 40 s	Less than 40 s
Response factor ²	1	1.5	2

¹ Lower explosion limit must be adhered to.

² The HC module is adjusted to methane in the factory. It can be adjusted to another gas by the user.



9.11 *Warranty periods*

Units:	2 years (apart from wear parts and measuring cells)
CO/NO/NO₂/SO₂/H₂S/HC sensors:	1 year
O₂ measuring cell:	1 ¹ / ₂ years
Probes:	1 year (apart from filter)
Rechargeable battery:	1 year
Accessories:	¹ / ₂ year
Printer:	1 year